

## Monosplit "Wall" type Air Conditioners "Personal Line Constant Speed" Models

Indoor Units:  
HKED 261 G  
HKED 351 G  
HKED 531 G



Outdoor Units:  
HCND 261 G  
HCND 351 G  
HCND 531 G



**Table of Contents**

**1. GENERAL INFORMATION ..... IG-1**

1.1 GUIDELINES TO CONSULTATION & WARNINGS .....IG-1

1.2 ESSENTIAL FEATURES OF THESE MODELS .....IG-2

1.3 APPEARANCE OF UNITS .....IG-7

1.4 OUTLINE OF INDOOR & OUTDOOR UNITS.....IG-15

1.5 IR REMOTE CONTROL .....IG-16

1.6 LED PANEL ON INDOOR UNITS.....IG-20

1.7 OPERATING USE CONDITIONS .....IG-21

1.8 HOW TO ADJUST AIR DIRECTION.....IG-22

1.9 EMERGENCY OPERATION & "SELF-CHECK" .....IG-24

1.10 AUTO-RESTART FUNCTON AFTER A BLACKOUT .....IG-26

1.11 SUGGESTIONS FOR ECONOMIC USE OF SYSTEM.....IG-27

**2. GENERAL TECHNICAL DATA ..... DG-1**

2.1 SPECIFICATIONS.....DG-1

2.2 DIMENSIONS OF UNITS.....DG-4

2.3 REFRIGERANT CIRCUIT DIAGRAM .....DG-9

**3. ELECTRICAL DATA..... DE-1**

3.1 WIRING DIAGRAMS .....DE-1

3.2 R/T FEATURES OF TEMPERATURE SENSORS .....DE-4

**4. CONTROL FUNCTIONS..... FU-1**

**5. INSTALLATION .....IN-1**

5.1 CHECKS AND PRELIMINARY OPERATIONS.....IN-3

5.2 INSTALLATION OF INDOOR UNITS HKED 261, 351, 531 G.....IN-6

5.3 INSTALLATION OF OUTDOOR UNITS HCND 261, 351, 531 G.....IN-21

5.4 VACUUM PROCEDURE AND REFRIGERANT CHARGE .....IN-29

**6. DIAGNOSTIC & MAINTENANCE.....DM-1**

6.1 AUTODIAGNOSIS OF MALFUNCTIONS: ERROR CODES ON INDOOR UNIT .....DM-2

6.2 FLOWCHARTS FOR MALFUNCTIONS' SOLUTION .....DM-4

6.3 CLEANING & MAINTENANCE OF AIR CONDITIONER .....DM-11

# 1. GENERAL INFORMATION

## 1.1 GUIDELINES TO CONSULTATION & WARNINGS

This Manual describes operation, installation and procedures for solving operation malfunctions of HOKKAIDO Air Conditioners Monosplit "Wall" Personal Line Constant Speed HKED-HCND 261, 351, 531 G".

This Manual is addressed to Installers and to Authorized Technical Service, that is charged to interventions for malfunction diagnosis and for repairing and/or servicing of system.

This Manual implies that Installers and Authorized Technical Service do know well the equipments and tools which are usually used for repairing electric, mechanical parts and refrigerant components of air-conditioning systems with R410A refrigerant. Furthermore, people who this Manual is addressed to should know terms of current use that are used for describing relevant operations.

In particular, it is recommended to read and follow carefully Safety Precautions and Warnings that are listed in this Manual. Missed observance of above prescriptions may lead to serious injuries to people, and even to death.

### ■ Relevant Documents

This Manual is not exhaustive about system operation, so it has to be consulted together with the User Manual, the Installation Sheets of Units and Spare Parts List referred to this Models of Units.

### ■ General Precautions and Warnings



In order to avoid the risk of death or of serious personal injuries caused by electric shocks, disconnect the power cable of Units before whatever intervention of repairing or maintenance.



In order to avoid the risk of death or of serious personal injuries caused by electric shocks, NEVER tamper with the ground wire for any reason. The appliance must always been equipped with a ground wire. Do not remove the Safety label referred to ground wire, which is on the power cable. If the electric system on installation site is not equipped of ground wire, please contact a qualified Electrician, for conforming electric system to current Regulations.



In order to avoid the risk of death or of serious personal injuries caused by overheating of the system's components, it is recommended to always make the system checked for verifying if there are malfunctions or if the system often stops suddenly.



In order to avoid the risk of death or of serious personal injuries caused by electric shocks, earth cables and cables whose sheath colour corresponds to ground wires, must not be used for power lines of Phase and Neutral. Standard colour of Ground wires is Green or Yellow/Green. The electric components such as compressor and fan motors are provided of an individual Ground wire, connected to a metal part of the appliance. When interventions of repairing or maintenance are carried out, the above Ground wires must not be disconnected, unless dismantling and replacing of components are needed. Before ending whatever intervention of repairing or maintenance, it is extremely important to connect again all Ground wires eventually disconnected before.

## 1.2 ESSENTIAL FEATURES OF THESE MODELS

### ➤ Energy high efficiency (Class A/A)

All capacities (261, 351, 531) of these systems meet requirements of Class "A" Energy Efficiency, both for operation in Cooling mode and for operation in Heating mode.

### ➤ "Ozone friendly" R410A refrigerant

R410A refrigerant does not damage ozone at all (ODP=0). Best performances assured by R410A refrigerant allow a sensible reduction in refrigerant amount, which is required for the operation of system. Both factors reduce the environmental impact of system.

### ➤ Advanced control for malfunction diagnosis

In case of eventual operation malfunctions, the most common among them will be shown by "Error Codes" on LED Display of Indoor Unit and by the status of "Running" LED  placed on Indoor Unit's frontal panel.

This allows targeted and therefore quicker interventions for solving of eventual malfunctions.

### ➤ Operation control by infrared remote control (IR)

On IR remote control, there is a wide range of options, that is:

☞ The possibility to program Timer operation ("Timer On", or "Timer Off") of system, within max. 24 hours, by steps of  $\pm 1$  hour.

☞ By "SLEEP" function, noise level of Indoor Unit can be reduced, as well as power consumption. This operation option, that foresees rotation of Indoor Unit's fan at Low speed and gradual "correction" of temperature set by remote control, is available both in Cooling mode and in Heating mode.

☞ "SWING" option: automatic swinging downwards and upwards of air outlet horizontal louver, for a uniform distribution of air supplied in the room by Indoor Unit.

☞ "Natural flow" option: sequence which consists in the upwards and downwards swinging of the air outlet horizontal louver, for twice, followed by a 30-seconds' stop of the louver and so on. This is for simulating a light air current in the room.

☞ "AIR FLOW" option: automatic swinging rightwards and leftwards of air outlet vertical louvers, for a uniform distribution of air supplied in the room by Indoor Unit.

### ➤ Automatic restart of Units after a power failure

☞ Normally, after 3 minutes since power is restored, the system is able to restart with the settings that were selected before the blackout. This means there is no need to press the "ON/OFF" button

☞ However, if "TIMER" operation had been previously selected, it will be cancelled and need to be set again.

☞ "SLEEP" function (see above), has to be expressly selected again as well.

☞ In the same way, if "SWING" and/or "AIR FLOW" options (see above) were active when the blackout occurred, they will be expressly selected again.

#### ➤ **Devices for a higher salubrity of air**

HKED 261, 351, 531 G Indoor Units are equipped of filters of mechanical type (net filters) at high efficiency air inlet, which can be easily reached for periodical cleaning.

#### ➤ **Advanced control of rotation of Indoor Unit's fan**

☞ During starting in Heating mode, indoor fan will start rotating only after Indoor Unit's heat exchanger has reached a temperature which avoids cold air supply by Indoor Unit. This "preheating" may require a time interval variable from 2 minutes to 5 minutes.

☞ During thermostatic pauses in Heating mode, indoor fan speed will be reduced to the lowest speed to avoid cold air supply by Indoor Unit.

☞ At the end of operation in Cooling mode, indoor fan will keep on rotating for a certain time interval since compressor's stop, so as to allow the removal of the humidity left over on Indoor Unit's heat exchanger. This logic of operation is in order to prevent humidity stagnation and the consequent forming of mould on Indoor Uni's heat exchanger.

#### ➤ **Operation in Heating mode with very low temperature**

These systems are able to operate in Heating mode also if outdoor temperature is very low: in fact, the lowest value of operating range in Heating mode is - 15°C. However, in these extreme conditions, as a consequence of the operation principle of "heat pump" systems, the performance of system will result remarkably reduced as regards environmental normal use conditions of the system itself.

#### ➤ **Appearance and functions: Indoor Units HKED 261, 351, 531 G**

☞ Operation in Emergency mode: also if the IR remote control is temporarily unavailable or malfunctioning, in any case it will be possible to start the system in "Auto Mode". To that end, it will be necessary to press the special button placed below the up-and-over frontal panel of Indoor Unit. Therefore, the control electronics will automatically select the operation mode, on the basis of temperature conditions inside the room.

☞ These Indoor Units have a new design, so as to fit harmoniously in residential environments.

☞ Moreover, for each capacity of Indoor Unit it is available on demand a range that includes 4 frontal decorative boards in different colours (available colours: "Black", "Gold", "Silver", "Light-Blue"), in

addition to the white decorative board preinstalled in factory. The installation of one of frontal decorative board allows to adapt Indoor Unit's appearance to different residential environments. This operation must be carried out only by qualified Personnel.

☞ On these Indoor Units there is a LED Display, of orange colour, with 2 alphanumeric characters, that is able to display alternatively the following information: set temperature value, remaining time (hours) of operation programmed by "Timer" function, starting up of automatic defrosting function or an eventual "Error Code" in case of a malfunction of the system. As a consequence of this, it is always possible to carry out an instant monitoring of the system's operation status.

☞ LED Display, which is always lighted up on these Models of Indoor Units, intensifies its brightness for about 10 seconds each time operation settings are changed by IR remote control. At the end of this time interval, LED Display's brightness softens. However, it is not possible to turn off LED Display completely.

➤ **Appearance and functions: Outdoor Units HCND 261, 351, 531 G**

☞ The frontal grill and the back grill of Outdoor Units are both treated against corrosion, and the same is true for bolts and fixation screws placed outside the chassis.

☞ The refrigerant fittings (service valves) and the electrical connections (terminal blocks) are protected from atmospheric agents (infiltrations of rainwater) by panels and service covers.

■ Recapitulatory outline of main available functions on Units

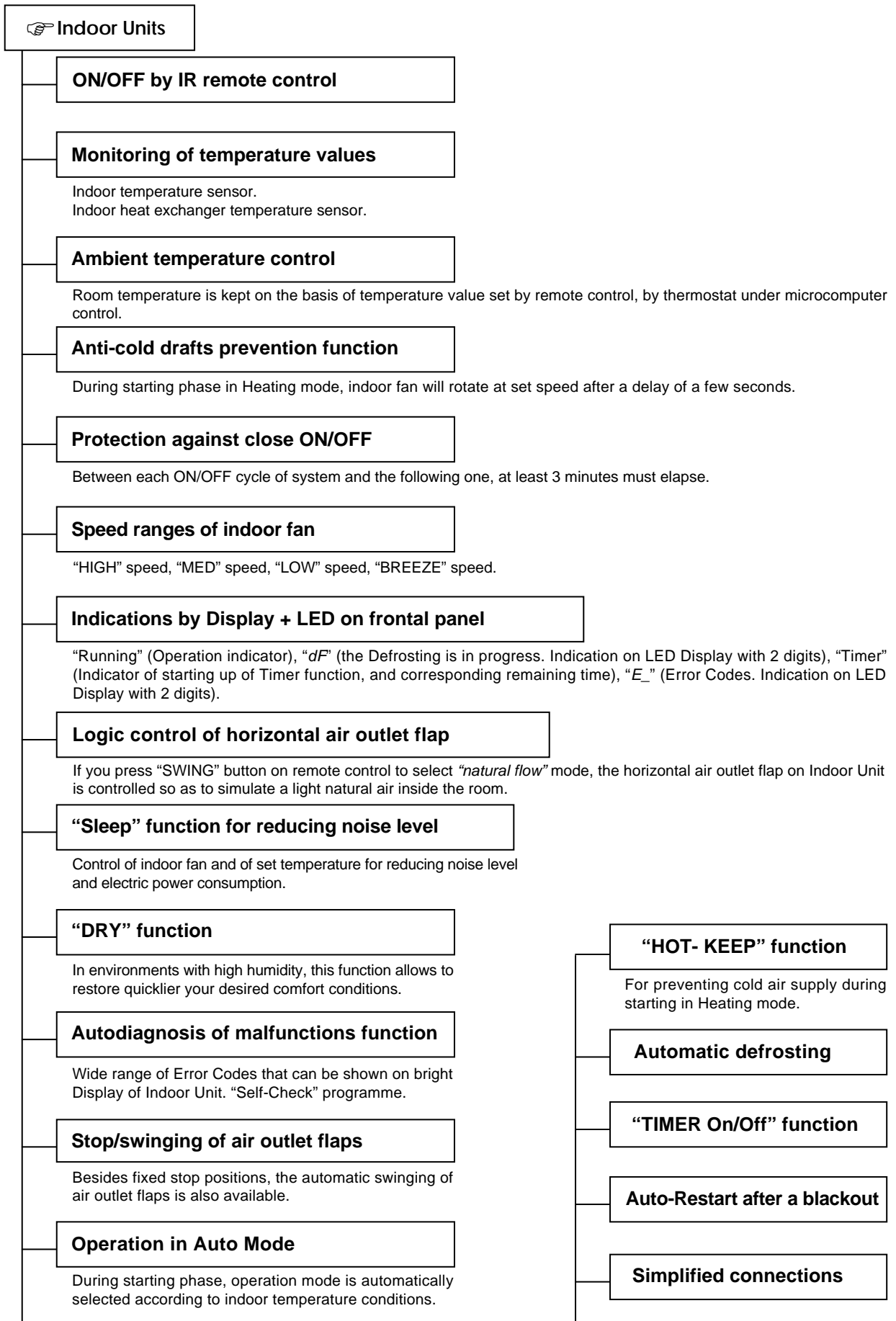

**Outdoor Units****Timed ON/OFF of compressor**

Min. interval between ON/OFF cycles of compressor is of 3 minutes.

**Outdoor fan with "silent" shape**

For reducing noise level of outdoor fan, the shape of fan wheel has been expressly redrawn.

**Special fins in treated aluminium**

Aluminium fins of outdoor heat exchanger ensure a higher efficiency in heat exchange.

**4-ways valve "energy saving" control**

It absorbs energy during operation in Heating mode only.

**Protection against compressor's overload****Anticorrosive surface treatment of chassis****Protection covers for electrical & refrigerant connections****Operation in Heating mode up to -15°C outdoor temperature**

### 1.3 APPEARANCE OF UNITS

#### ■ Indoor Units "Wall" Personal Line Constant Speed (On-Off):

##### Model HKED 261 G



Frontal board, standard "White" (by factory)

##### Model HKED 261 G



Frontal board, optional "Black" (HSD-1-BCK)

##### Model HKED 261 G

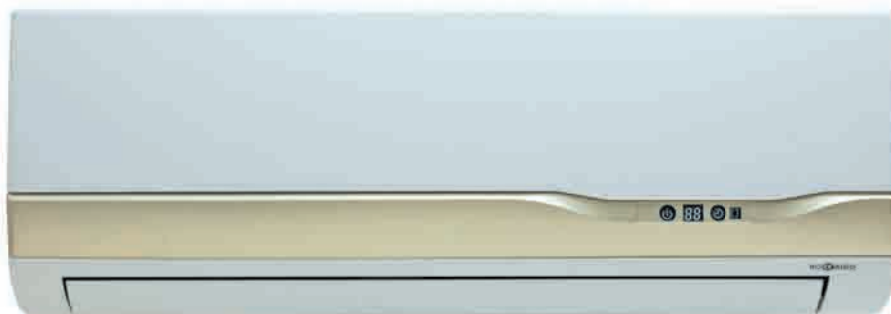

Frontal board, optional "Gold" (HSD-1-GLD)

**■ Indoor Units "Wall" Personal Line Constant Speed (On-Off):****Model HKED 261 G**

Frontal board, optional "Silver" (HSD-1-SLV)

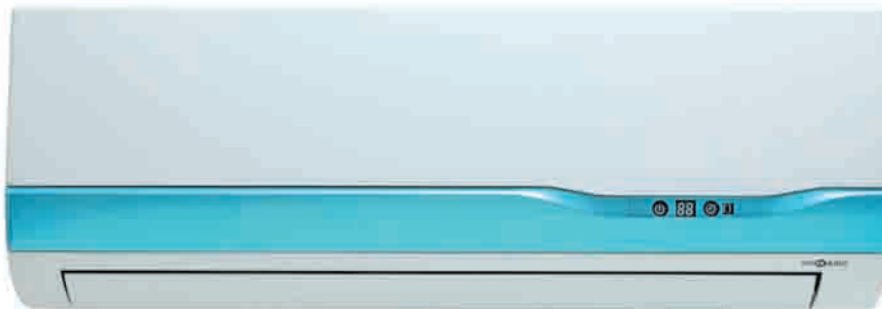
**Model HKED 261 G**

Frontal board, optional "Light-Blue" (HSD-1-LBL)

**■ Indoor Units "Wall" Personal Line Constant Speed (On-Off):****Model HKED 351 G**

Frontal board, standard "White" (by factory)

**Model HKED 351 G**

Frontal board, optional "Black" (HSD-2-BCK)

**Model HKED 351 G**

Frontal board, optional "Gold" (HSD-2-GLD)

**■ Indoor Units "Wall" Personal Line Constant Speed (On-Off):****Model HKED 351 G**

Frontal board, optional "Silver" (HSD-2-SLV)

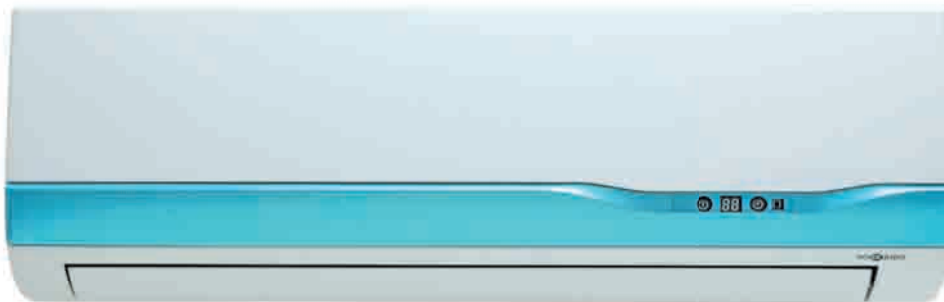
**Model HKED 351 G**

Frontal board, optional "Light-Blue" (HSD-2-LBL)

**■ Indoor Units "Wall" Personal Line Constant Speed (On-Off):****Model HKED 531 G**

Frontal board, standard "White" (by factory)

**Model HKED 531 G**

Frontal board, optional "Black" (HSD-3-BCK)

**Model HKED 531 G**

Frontal board, optional "Gold" (HSD-3-GLD)

**■ Indoor Units "Wall" Personal Line Constant Speed (On-Off):****Model HKED 531 G**

Frontal board, optional "Silver" (HSD-3-SLV)

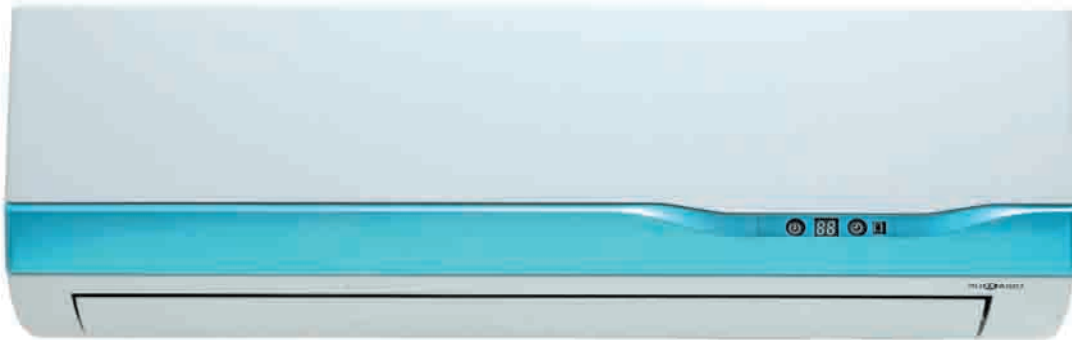
**Model HKED 531 G**

Frontal board, optional "Light-Blue" (HSD-3-LBL)

**■ Outdoor Units Personal Line Constant Speed (On-Off):****Model HCND 261 G****Model HCND 351 G**

**■ Outdoor Units Personal Line Constant Speed (On-Off):****Model HCND 531 G**

### 1.4 OUTLINE OF INDOOR & OUTDOOR UNITS

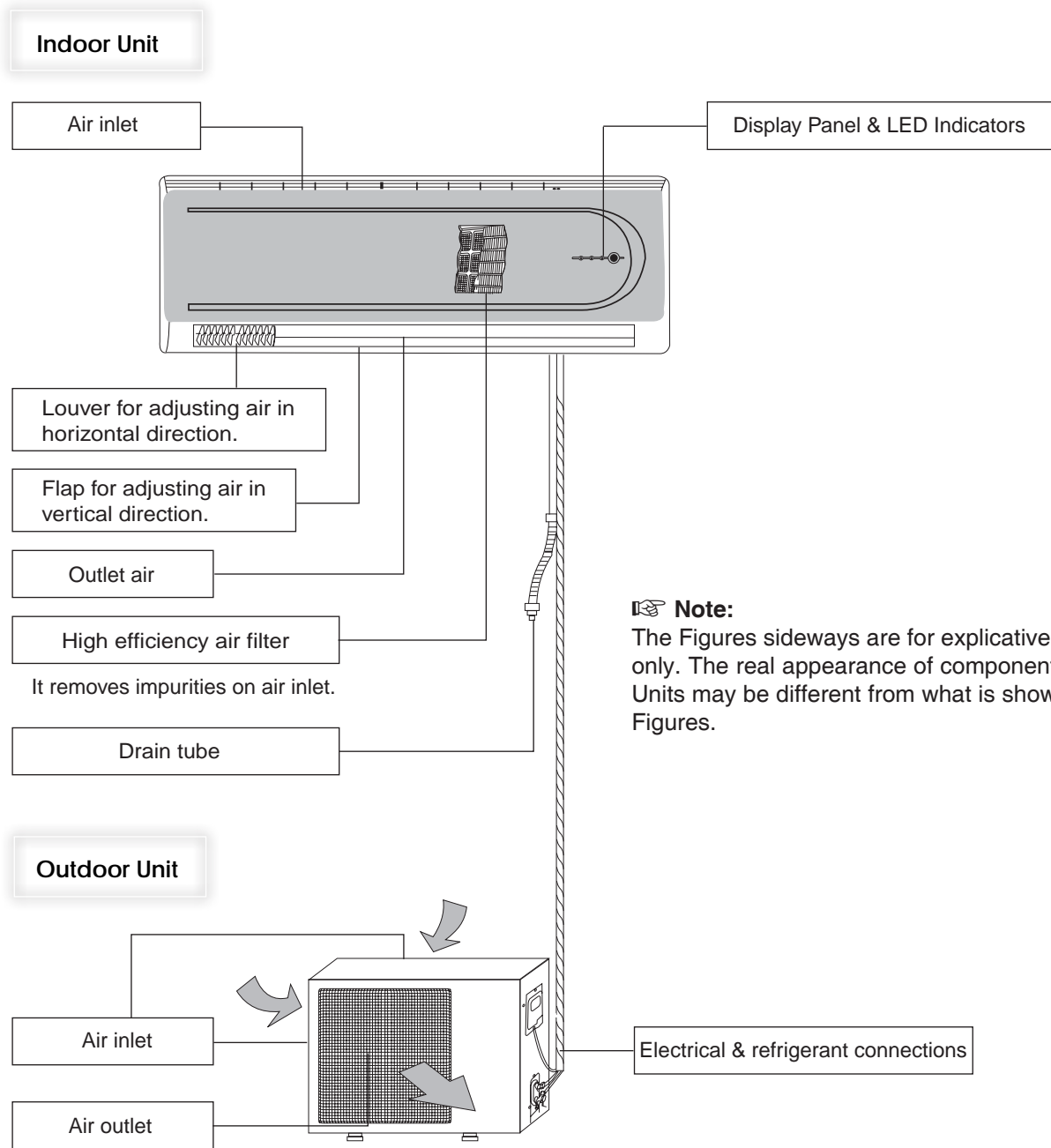

#### ■ Frontal panel of Indoor Unit

a) Panel's opening

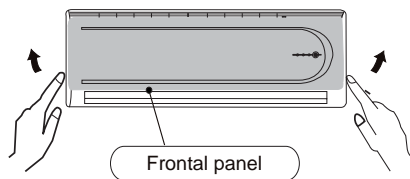

- Press both sides of panel and pull the panel towards you till max. opening angle (about 60° as regards vertical position).
- Never force the panel more than max. opening angle.

b) Panel's closing

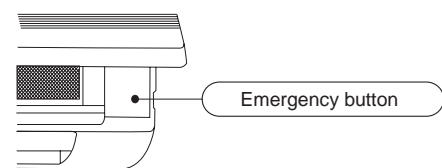

- Below the panel there is the Emergency Button, which allows operation (in Auto Mode) if IR remote control is not available.
- Push the panel downwards till closing position, indicated by the "click" of blockage mechanism.

## 1.5 IR REMOTE CONTROL

### ■IR Remote Control for Models HKED (261, 351, 531) G



#### Notes:

○For a detailed explication concerning the function of each button of IR remote control, and concerning symbols which are shown on remote control's LCD Display, please refer to the "User Manual" provided with Indoor Units, or to the following pages.

○For a detailed explication about options and operation modes of system, please refer to the "User Manual" provided with Indoor Units.

○Concerning these Models HKED-HCND (261, 351, 531) G (On-Off), even if "TURBO" button and "LAMP" button are available on remote control, they refer to unavailable functions. Consequently, if you press these buttons, there will be no effect on these systems.

■ Outline of IR remote control's buttons

**Set Temperature**

These buttons allow to adjust ambient temperature.  
 If you press "+" button, set temperature is increased by 1°C.  
 If you press "-" button, set temperature is reduced by 1°C.  
 The range of temperatures that can be set is the following: 16°C ~ 32°C.  
 (In "AUTO" mode and in "DRY" mode, temp. is automatically set to 25°C and cannot be modified by the User).





**Operation Mode**

To select operation mode:

- "AUTO"
- "COOL"
- "DRY"
- "HEAT"
- "FAN"

**Fan Speed**

To change fan speed:

- LOW: 
- MED: 
- HIGH: 
- AUTO:  (flashing).

**"Turbo" Button**

In COOL and HEAT modes, if you press this button, operation in "Turbo" mode is started up.  
**This function is not available on these Models On-Off.**

**"Timer" Button**

To programme the automatic start (TIMER ON) or the automatic stop (TIMER OFF) of system.

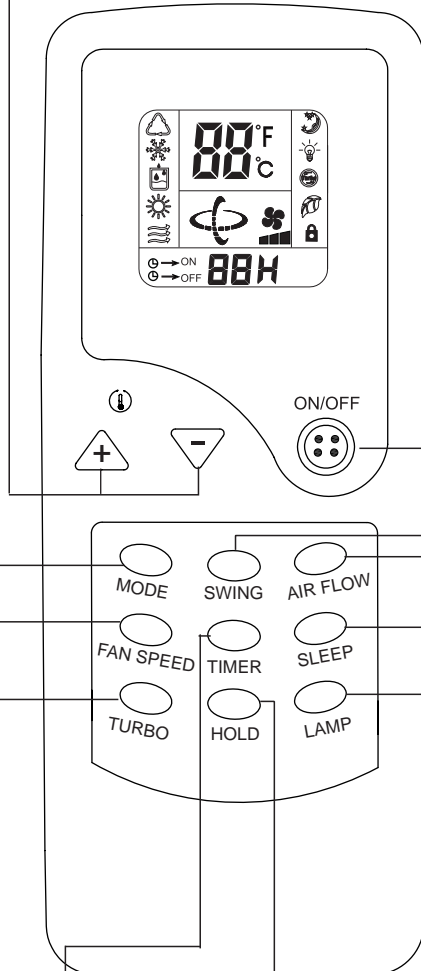



**"ON/OFF" Button**

To start/stop the system.

**"SWING" Button**

To adjust motorized flap for air outlet in vertical direction (up/down):

- "natural flow":  (ON).
- Swinging:  (flashing).
- Fixed position:  (ON).

In "DRY" mode, the flap's angle is adjusted in fixed position.

**"AIR FLOW" Button**

To select position of motorized louvers for air outlet in horizontal direction (left/right).  
 Flaps may swing continuously, or stop in fixed position.

**"SLEEP" Button**

To select operation in "SLEEP" mode.

**"LAMP" Button**

To light up/go out the Display on the Indoor Unit.  
**This button is not operating on these Models.**

**"HOLD" Button**

To lock/unlock all buttons of remote control.

■ Reception of signals transmitted to Indoor Unit

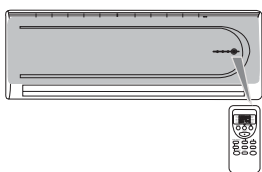

○ If buttons of remote control are pressed by orienting correctly remote control itself towards the IR receiver on Indoor Unit, signals will be transmitted to Indoor Unit.

○ If signals have been correctly received, the buzzer on Unit emits a sound.

■ Outline of symbols on IR remote control's Display

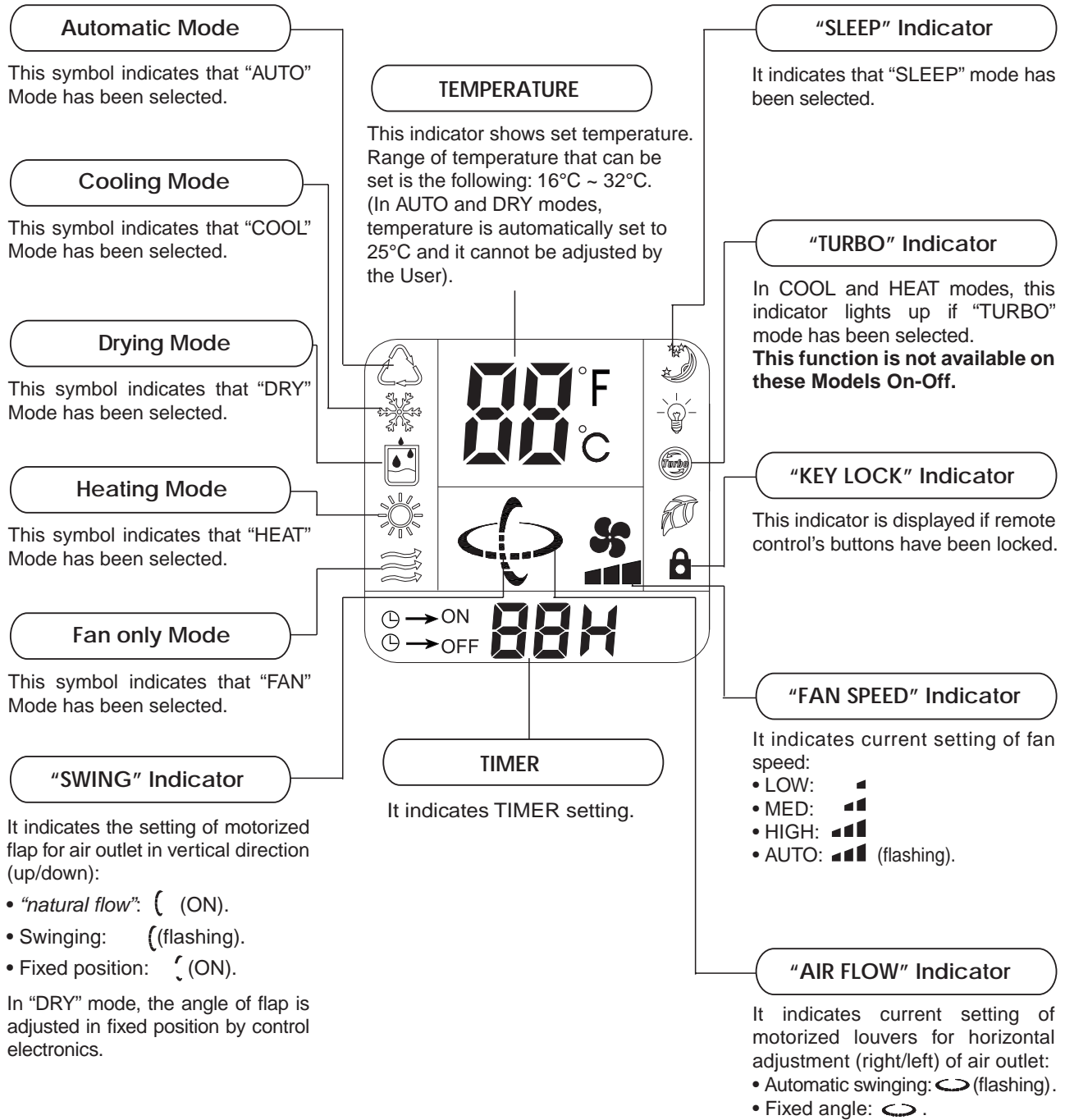

**Notes:**  
 ○The Figure above shows all possible indications that can be displayed on IR remote control's Display.  
 ○In reality, only indications referred to current operation selections will be displayed.

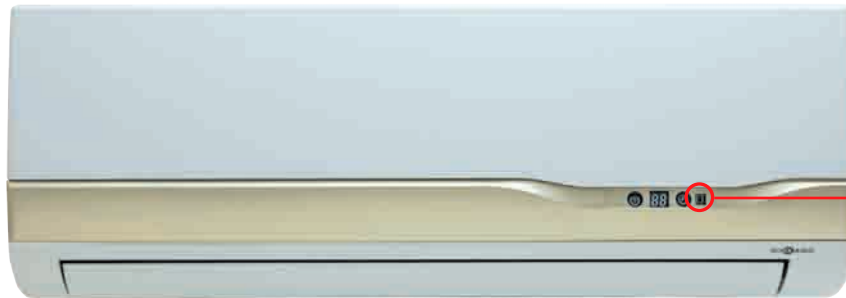
**■ Recommendations for the correct use of IR remote control**

IR receiver for remote control

Maximum allowed distance: 8 metres



- ☞ Make sure that batteries ("AAA" type, 1.5V) are fully charged and correctly fitted in the special case on remote control, by respecting the polarity marked on remote control itself. The average life of batteries is of about 1 year. Never use rechargeable batteries.
- ☞ Use the remote control by turning it towards the Indoor Unit at no more than 8 metres from the Unit's IR receiver.
- ☞ Remote control will not work properly if curtains, doors or other objects placed between remote control and Indoor Unit's IR receiver do not allow the transmission of signals sent to Indoor Unit. In these cases, the operating range of remote control will be remarkably reduced.
- ☞ If remote control is placed sideways as regards the signal receiver, remote control will operate within a maximum angle of 30° on the right or on the left of receiver. If remote control is fixed on its wall bearing, it will work within a side max. distance of 0.5 metres on the right or on the left of receiver.
- ☞ If IR receiver on Indoor Unit is exposed to direct sunlight, remote control (and consequently the air conditioner) may not work properly.
- ☞ In order to avoid interferences, keep remote control at least 1 metre away from Hi-Fi, TV, etc.
- ☞ If remote control does not work properly, press "RST" button (reset of settings) placed on the back of the remote control itself. Check if remote control do operate properly now. Otherwise, remove both batteries from remote control, then wait for a few minutes and reinstall batteries in their case.
- ☞ Never wet the remote control and prevent any liquid from falling on it.
- ☞ Do not use any liquid, solvent or detergent for cleaning the remote control. Use only a soft cloth, clean and dry.

## 1.6 LED PANEL ON INDOOR UNITS

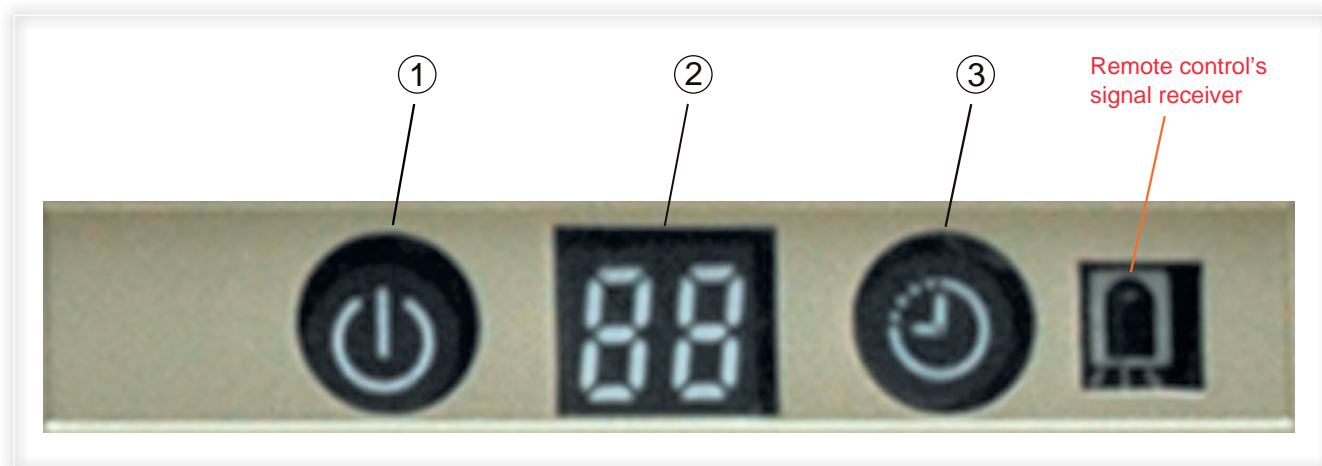

### ① "Running" LED (Orange):

- It lights up when the Indoor Unit is operating.
- It flashes (once / 3seconds) when at operation start in Heating mode, the preheating of heat exchanger on Indoor Unit is in progress (Indoor Unit's fan is still stopped).
- It flashes in different ways (see "Section 6: Diagnostic & Maintenance" of this Technical Manual) when a system's malfunction occurs.

### ② LED Display with 2 alphanumeric characters (Orange):

- During normal operation, it displays temperature value set by IR remote control.
- If one of Timer options has been selected ("TIMER ON", or "TIMER OFF"), the remaining time interval (in hours) before automatic start/stop is displayed. The same remaining interval time is displayed on remote control's LCD Display.
- While automatic defrosting is in progress (with reversal of refrigerant cycle as regards operation in Heating mode), LED Display shows "dF" indication.
- If control electronics diagnoses a malfunction which is in the list of codified malfunctions, LED Display shows the corresponding Error Code [E \_]. For the list of Error Codes and malfunctions' solutions, refer to "Section 6: Diagnostic & Maintenance" of this Technical Manual.

### ③ "Timer" LED (Orange):

- It light up when one of Timer options has been selected ("Timer On", or "Timer Off").

#### 🔧 "LED Display" function:

- LED Display, always lighted up on these Models of Indoor Units "Constant Speed", intensifies for about 10 seconds each time a change of operation settings is carried out by IR remote control.
- At the end of this time interval, the brightness of LED Display softens.

**1.7 OPERATING USE CONDITIONS**

☞ In order to obtain the best performances from the appliance, it is recommended its use under the following temperature conditions:

Operation Mode Temperatures	Cooling	Heating
Ambient temperature	16°C	32°C
Outdoor temperature	+ 5°C ~ + 45°C	- 15°C ~ + 24°C

☞ Use of the air conditioner out of the above mentioned temperature range could cause the intervention of built-in protection functions consequently stopping the system operation.

☞ Relative humidity inside the room should always be less than 80%. Otherwise, condensate may drip during operation in Dry mode, or frost may form on indoor heat exchanger during operation in Cooling mode.

**☞ Note:**

- If the appliance operates in rooms which are saturated with oil vapors or volatile matters, harmful substances could coat and clog the indoor heat exchanger. Besides, scalings of saltiness could form on the Outdoor Units installed in sea-surroundings; if not removed, they will damage the Units in a very short time.
- In both cases, please contact the Authorized Technical Service to require frequent maintenance.



## 1.8 HOW TO ADJUST AIR DIRECTION

### ■ Adjustment of airflow in vertical direction

Carry out this adjustment according to your comfort needs, and avoid to direct airflow to people, plants and animals.

Angle of airflow in vertical direction can be set by remote control.

#### ■ How to orient airflow in vertical direction:

<p><b>a) Optimized airflow or fixed position</b></p> <ul style="list-style-type: none"> <li>○ Control electronics adjusts in optimal way ("natural flow") the movement of horizontal flap so as to simulate a light air current inside the room.</li> <li>In this case, remote control's display will show the indicator .</li> <li>○ If you would like to change the angle of horizontal flap as regards default setting for each operation mode, press "SWING" button twice, till fixed default position is reached.</li> <li>In this case, remote control's display will show the indicator .</li> <li>○ Carry out these adjustments while the system is operating.</li> </ul>	<p><b>b) Continuous swinging ("SWING")</b></p> <ul style="list-style-type: none"> <li>○ Carry out this adjustment while the system is operating.</li> <li>○ Press (once or twice) "SWING" button till reaching continuous swinging in vertical direction (up/down) of horizontal airflow flap.</li> <li>In this case, remote control's display will show the flashing indicator .</li> <li>○ Press "SWING" button again to go back to default fixed position of horizontal flap for each operation mode.</li> <li>○ Carry out these adjustments while the system is operating.</li> </ul>
---	--

### CAUTION

- If system is OFF, "SWING" button does not start any function.
- Do not operate system for a long time with horizontal flap completely addressed downwards in Cooling mode and in Dry mode, to avoid that condensate forms on the flap itself, and that condensate may drip inside the room.
- When air conditioner is started, the horizontal flap will start moving after a certain time, that is after inner electronics has undertaken its control.
- If system is stopped by remote control, and air conditioner was operating in Cooling mode or in Dry mode, horizontal flap will automatically move to closing position only after about 30 seconds. This allows to remove the remaining humidity from Indoor Unit's heat exchanger and prevent the forming of mould.
- If horizontal flap does not work properly, stop the system, disconnect it and wait for a few minutes. Then connect it again, start it and check if horizontal flap is operating properly now.
- The angle of horizontal flap must never be too much small, to avoid a too much choking of air outlet and consequent lowering in performances.
- Room relative humidity should always be lower than 80%. If air conditioner is operating in Cooling mode at higher levels of humidity, the surface of indoor heat exchanger may get covered with frost (till causing the intervention of special protective function). If this occurs, please adjust horizontal flap



to air outlet max. angle, and in Cooling mode, select "High" fan speed.

○When system is connected, each flap motor may emit a light whirr for about 10 seconds, however this is not a malfunction.

○Never try to move horizontal flap manually, but adjust it by using remote control only. In this way, adjustment mechanism will not be damaged.

**■ Adjustment of airflow in horizontal direction**

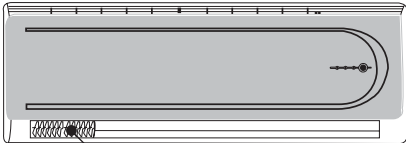
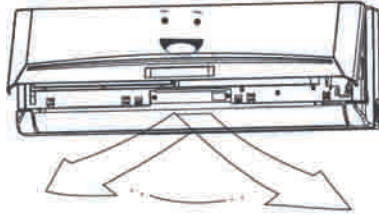
Airflow supply in horizontal direction can be adjusted by IR remote control, through "AIR FLOW" button.

 <p>Vertical louver for adjusting airflow in horizontal direction.</p>  <p>Continuous swinging of louver</p>	<p><b>■ Adjusting airflow in horizontal direction:</b></p> <ul style="list-style-type: none"> <li>○ Carry out this adjustment when the system is operating.</li> <li>○ Press "AIR FLOW" button on remote control to select horizontal direction (left/right) for airflow supply.</li> <li>○ On IR remote control's display display may appear the following indications:</li> </ul> <p> <b>Flashing indicator.</b> Automatic swinging of air outlet vertical louver has been set.</p> <p> <b>Fixed indicator.</b> A fixed position for air outlet vertical louver has been set.</p> <p><b>☞ Note:</b></p> <ul style="list-style-type: none"> <li>○ The adjustment of airflow in horizontal direction is available in all operation modes of system.</li> </ul>
--	--

**CAUTION**

○When the system is OFF, "AIR FLOW" button does not start any function.

○Never try to move vertical louver manually, but adjust it by using remote control only. In this way, Adjustment mechanism will not be damaged.

**1.9 EMERGENCY OPERATION & "SELF-CHECK"**

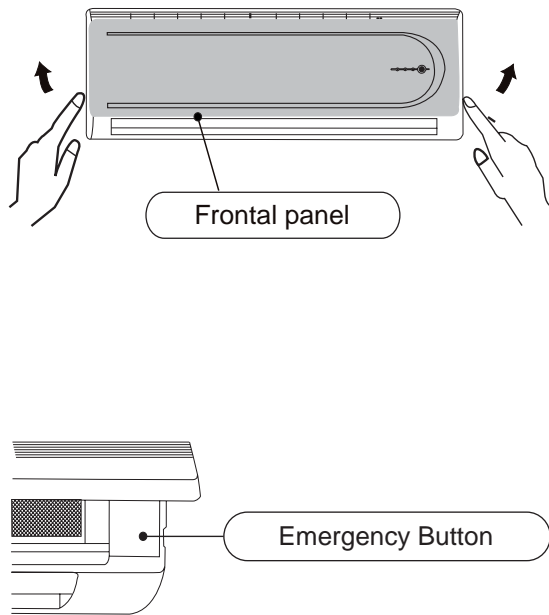

○ **Access to Emergency Button:**

For reaching Emergency Button, open frontal panel.

○ **Opening of frontal panel:**

Seize both side ends of frontal panel. Pull the panel towards you and lift it till hearing the click of limit end. Do not force the opening of panel because this causes the breaking of hinges.

○ **Closing of frontal panel:**

Seize both side ends of frontal panel, and pull it down towards Indoor Unit's body. Gently push the panel till completely closing it.

○ **Emergency Operation:**

If remote control is temporarily unavailable or batteries are exhausted, nevertheless it is possible to use the air conditioner by pressing Emergency Button once while the system is OFF.

In this way, Emergency operation in "AUTO" mode will be started up, and the system will operate in the most suitable mode according to temperature conditions inside the room, with temperature value (the so-called "set point") set to 25°C (not modifiable value).

☞ **In particular, it occurs the following:**

If room temperature is lower than 21°C, operation in "HEAT" mode will be selected.

If room temperature is 21°C ~ 26°C, operation in "FAN" mode will be selected.

If room temperature is higher than 26°C, operation in "COOL" mode will be selected.

○ **End of Emergency Operation**

Press Emergency Button again during Emergency operation: system's operation will be stopped (OFF).

Besides, during Emergency operation it is sufficient to press ON/OFF button on remote control to restore normal operation of system.

○ **"Self-Check" Mode (quick autodiagnosis of malfunctions)**

You can enter this diagnostic mode by connecting the system through main power switch, and at the same time by pressing Emergency Button on Indoor Unit.

☞ All indicators on Indoor Unit's LED Display will light up in sequence and afterwards will go out, if no malfunction can be diagnosed by control electronics. Otherwise, an Error Code ("E\_") will be displayed and at the same time "Running" LED  on frontal panel of Indoor Unit will flash according to the codification referred to the kind of malfunction (see "*Section 6: Diagnostic & Maintenance*" of this Technical Manual).

### 1.10 AUTO-RESTART FUNCTION AFTER A BLACKOUT

☞ A blackout during system's operation, immediately causes the system's stop.

☞ When power is restored, Operation LED ("Running")  on Indoor Unit will start blinking.

☞ Normally, if the system was ON when the blackout occurred, it is able to automatically restart after 3 minutes have elapsed since power is restored.

Therefore, it is not necessary to press ON/OFF button on remote control, except for accidental deletion of operation data memory (EEPROM). In this case only, the system cannot automatically restart, and it will be necessary to use the IR remote control or the Emergency Button.

☞ At the end of the blackout, the system's operating setting will be the same as when the system stopped.

☞ Automatic start/stop of air conditioner, programmed by "Timer On/Off" functions, or the starting up of "SLEEP" function will be cancelled so a new "TIMER" setting or "SLEEP" setting must be carried out.

**CAUTION**

☞ **If the system is used to air-condition an environment where people live occasionally, it is recommended to stop it before leaving the building and to disconnect the system by main switch, and/or disconnect the plug from the power socket, such as additional safety measure.**

Move main switch to OFF

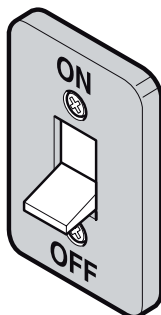

Disconnect the plug from the power socket

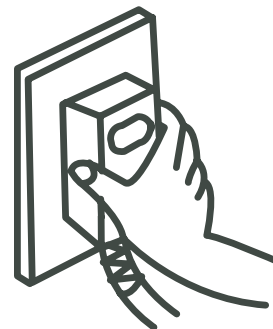

**1.11 SUGGESTIONS FOR ECONOMIC USE OF SYSTEM**

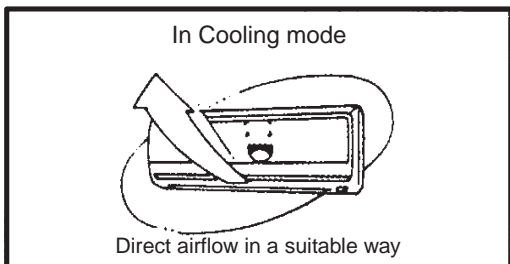
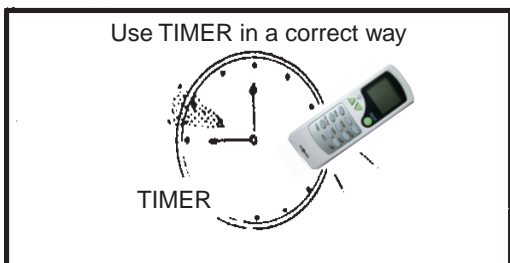
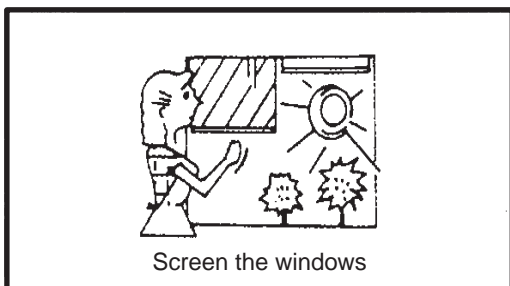
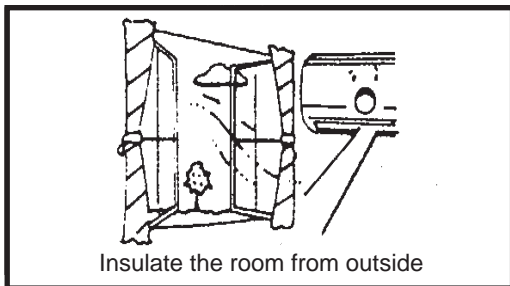
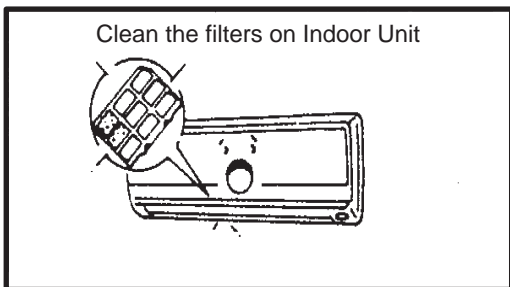
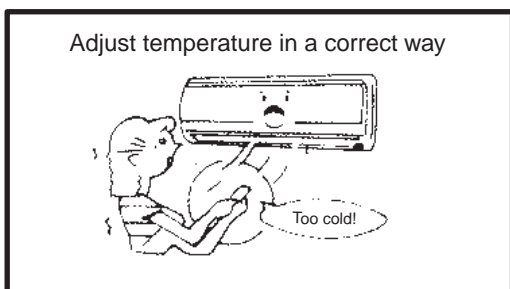

- **Set a suitable temperature value:**

  - During operation in Heating mode, avoid to set a too high temperature value.
  - During operation in Cooling mode, avoid to set a too low temperature value.
  
- **Often clean air filters:**

  - To keep air conditioner in perfect efficiency, it is necessary to clean filters on Indoor Unit at least every 2 weeks, as it is described in the "User Manual" of these systems.
  - If there is a lot of dust on filters, the system's performances will be reduced.
  
- **Avoid to keep door and windows always open:**

  - This reduces the system's performances and causes an increase in electric power consumption.
  - Moreover, in case of thermic overload, it may occur the intervention of protective automatic functions of appliance, with consequent stop of system itself.
  
- **Limit exposure to sunlight:**

  - During operation in Cooling mode, it is recommended to screen by curtains the windows exposed to sunlight during the warmest hours of day.
  - In this way, you will experience substantial increase in comfort and a reduction in power supply consumption.
  
- **Use "TIMER" function according to real needs:**

  - Do not programme operation for time intervals longer than real comfort needs, by considering above all the real stay of people in the air-conditioned room.
  
- **Adjust the airflow direction:**

  - With some practice, it will be possible to evaluate by yourself the increase in comfort that results from a correct adjustment of airflow direction. In this way, electric power consumption being equal, comfort remarkably increases.

## 2. GENERAL TECHNICAL DATA

### 2.1 SPECIFICATIONS

HOKKAIDO			HKED 261 G - HCND 261 G
Power Supply		Ph-V-Hz	1- 220 ~ 240V- 50Hz
Cooling	Cooling capacity	kW	2.68
	Power input (Cooling)	kW	0.835
	Input Rated Current	A	3.4
	EER / Energy Level Class	-	3.21 / A
	Annual Consumption (500h)	kW	418
Heating	Heating capacity	kW	2.97
	Power input (Heating)	kW	0.817
	Input Rated Current	A	3.4
	COP / Energy Level Class	-	3.63 / A
Drying capacity		L/h	1.0
Max. current (starting current)		A	8.0
Compressor	Model	-	-
	Type	-	Rotary
	Brand	-	Toshiba
Heat exchanger (Indoor Unit)	Finning material	-	Treated aluminium
Drain hose diameter (Indoor Unit)		mm	Ø16.5
Air treated by Indoor Unit ("High" speed)		m <sup>3</sup> /h	500
Noise level Indoor Unit (H / M / L), 1 m		dB(A)	39 / - / 29
Indoor Unit	Dimensions (L x H x P)	mm	745 x 250 x 195
	Packaging (L x H x P)	mm	845 x 330 x 278
	Net/Gross Weight	kg	9 / 11
Heat exchanger (Outdoor Unit)	Finning material	-	Treated aluminium
Air treated by Outdoor Unit (Max.)		m <sup>3</sup> /h	1700
Noise level Outdoor Unit, 1 (2.5) m		dB(A)	50 (42)
Outdoor Unit	Dimensions (L x H x P)	mm	700 x 500 x 225
	Packaging (L x H x P)	mm	825 x 550 x 320
	Net / Gross Weight	kg	25 / 29
Refrigerant / Precharged amount + additional refrigerant charge		g	R410A / 560 (refrigerant precharge up to 3.5m) + 30 g/m
Operating pressure inside the circuit		MPa	4.2
Refrigerant pipings	ØLiquid Side / ØGas Side	mm (inches)	6.35 (1/4") / 9.52 (3/8")
	Max. splitting distance (liquid)	m	15
	Max. splitting level difference between Units	m	5
Wiring between Units		n. (section)	4 (1.5mm <sup>2</sup> ) + Earth cable
Power supply plug (Indoor Unit)		A	10A
Remote control		-	IR Remote Control
Temperature range that can be set		°C	+16 ~ +32
Operating temperature range (Cooling)		°C	- 15 ~ +24
Operating temperature range (Heating)		°C	0 ~ +45



Light-Blue



Gold



Silver



White



Black

<b>HOKKAIDO</b>			<b>HKED 351 G - HCND 351 G</b>
<b>Power Supply</b>		<b>Ph-V-Hz</b>	<b>1- 220 ~ 240V- 50Hz</b>
<b>Cooling</b>	Cooling capacity	kW	3.50
	Power input (Cooling)	kW	1.090
	Input Rated Current	A	5.1
	EER / Energy Level Class	-	3.21 / A
	Annual Consumption (500h)	kW	545
<b>Heating</b>	Heating capacity	kW	3.95
	Power input (Heating)	kW	1.090
	Input Rated Current	A	4.8
	COP / Energy Level Class	-	3.62 / A
Drying capacity		L/h	1.2
Max. current (starting current)		A	9.9
<b>Compressor</b>	Model	-	-
	Type	-	Rotary
	Brand	-	Toshiba
Heat exchanger (Indoor Unit)	Finning material	-	Treated aluminium
Drain hose diameter (Indoor Unit)		mm	Ø16.5
Air treated by Indoor Unit ("High" speed)		m³/h	500
Noise level Indoor Unit (H / M / L), 1 m		dB(A)	39 / - / 29
<b>Indoor Unit</b>	Dimensions (L x H x P)	mm	800 x 280 x 190
	Packaging (L x H x P)	mm	865 x 358 x 275
	Net / Gross Weight	kg	12 / 14
Heat exchanger (Outdoor Unit)	Finning material	-	Treated aluminium
Air treted by Outdoor Unit (Max.)		m³/h	1900
Noise level Outdoor Unit, 1 (2.5) m		dB(A)	52 (44)
<b>Outdoor Unit</b>	Dimensions (L x H x P)	mm	795 x 540 x 255
	Packaging (L x H x P)	mm	920 x 595 x 335
	Net / Gross Weight	kg	38 / 42
Refrigerant / Precharged amount + additional refrigerant charge		g	R410A / 970 (refrigerant recharge up to 3.5m) + 30 g/m
Operating pressure inside the circuit		MPa	4.2
Refrigerant pipings	ØLiquid Side / ØGas Side	mm (inches)	6.35 (1/4") / 9.52 (3/8")
	Max. splitting distance (liquid)	m	15
	Max. splitting level difference between Units	m	5
Wiring between Units		n. (section)	4 (1.5mm²) + Earth cable
Power supply plug (Indoor Unit)		A	20A
Remote control		-	IR Remote Control
Temperature range that can be set		°C	+16 ~ +32
Operating temperature range (Cooling)		°C	- 15 ~ +24
Operating temperature range (Heating)		°C	0 ~ +45



Light-Blue



Gold



Silver



White



Black

HOKKAIDO		HKED 531 G - HCND 531 G	
Power Supply		Ph-V-Hz	1- 220 ~ 240V- 50Hz
Cooling	Cooling capacity	kW	5.30
	Power input (Cooling)	kW	1.650
	Input Rated Current	A	6.8
	EER / Energy Level Class	-	3.21 / A
	Annual Consumption (500h)	kW	825
Heating	Heating capacity	kW	5.85
	Power input (Heating)	kW	1.620
	Input Rated Current	A	6.8
	COP / Energy Level Class	-	3.61 / A
Drying capacity		L/h	1.7
Max. current (starting current)		A	12.5
Compressor	Model	-	-
	Type	-	Rotary
	Brand	-	Toshiba
Heat exchanger (Indoor Unit)	Finning material	-	Treated aluminium
Drain hose diameter (Indoor Unit)		mm	Ø16.5
Air treated by Indoor Unit ("High" speed)		m³/h	800
Noise level Indoor Unit (H / M / L), 1 m		dB(A)	44 / - / 37
Indoor Unit	Dimensions (L x H x P)	mm	900 x 292 x 215
	Packaging (L x H x P)	mm	983 x 377 x 300
	Net / Gross Weight	kg	17 / 19
Heat exchanger (Outdoor Unit)	Finning material	-	Treated aluminium
Air treated by Outdoor Unit (Max.)		m³/h	2000
Noise level Outdoor Unit, 1 (2.5) m		dB(A)	52 (44)
Outdoor Unit	Dimensions (L x H x P)	mm	795 x 540 x 255
	Packaging (L x H x P)	mm	920 x 595 x 335
	Net / Gross Weight	kg	42 / 46
Refrigerant / Precharged amount + additional refrigerant charge		g	R410A / 1550 (refrigerant precharge up to 3.5m) + 30 g/m
Operating pressure inside the circuit		MPa	4.2
Refrigerant pipings	ØLiquid Side / ØGas Side	mm (inches)	6.35 (1/4") / 12.7 (1/2")
	Max. splitting distance (liquid)	m	15
	Max. splitting level difference between Units	m	5
Wiring between Units		n. (section)	4 (2.5mm²) + Earth cable
Power supply plug (Indoor Unit)		A	20A
Remote control		-	IR Remote Control
Temperature range that can be set		°C	+16 ~ +32
Operating temperature range (Cooling)		°C	- 15 ~ +24
Operating temperature range (Heating)		°C	0 ~ +45



**2.2 DIMENSIONS OF UNITS**

■ Indoor Unit HKED 261 G

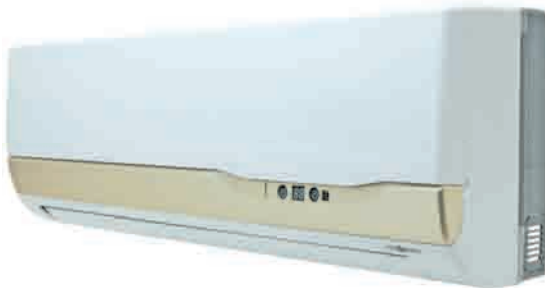
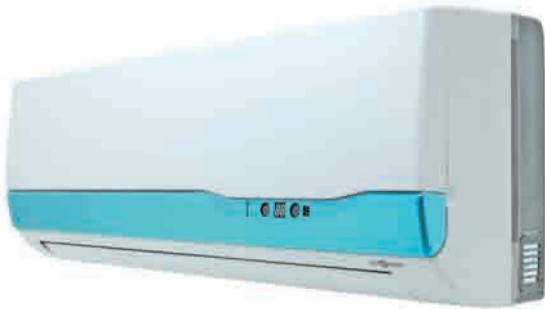

Unit: mm

Dimensions	Width	Height	Depth
Model			
<b>HKED 261 G</b>	745	250	195

■ Indoor Unit HKED 351 G

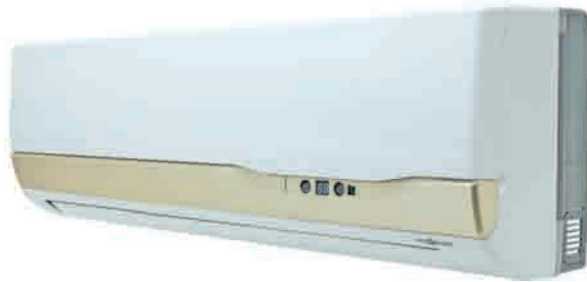
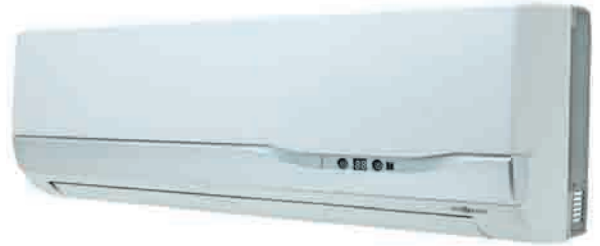
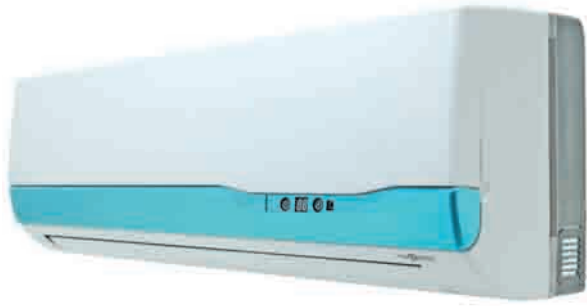

Unit: mm

Model	Dimensions		
	Width	Height	Depth
<b>HKED 351 G</b>	800	280	190

■ Indoor Unit HKED 531 G

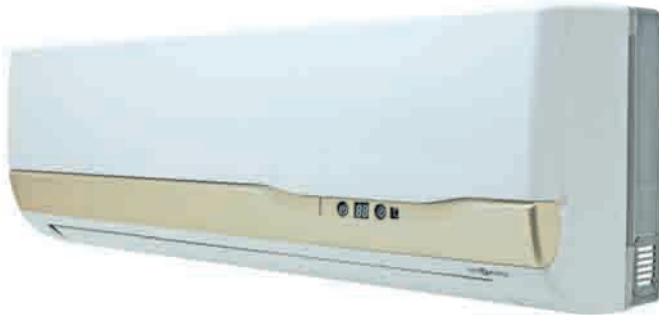
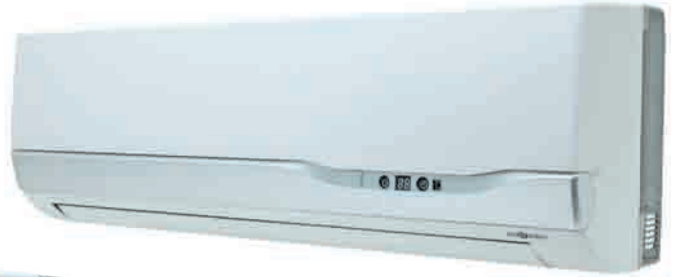
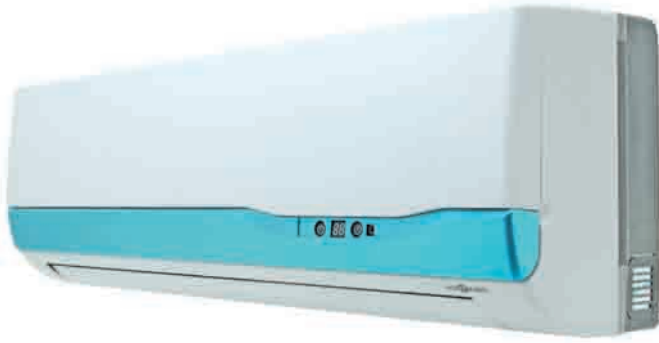

Unit: mm

Dimensions	Width	Height	Depth
Model			
<b>HKED 531 G</b>	900	292	215

■ Outdoor Unit HCND 261 G



Unit: mm

Dimensions Model	Width	Height	Depth
<b>HCND 261 G</b>	700	500	225

■ Outdoor Unit HCND 351 G



Unit: mm

Dimensioni Modelli	Width	Height	Depth
<b>HCND 351 G</b>	795	540	255

## ■ Outdoor Unit HCND 531 G



Unit: mm

Dimensions	Width	Height	Depth
Model			
<b>HCND 531 G</b>	795	540	255

**2.3 REFRIGERANT CIRCUIT DIAGRAM**

■ Models HKED - HCND 261, 351, 531 G

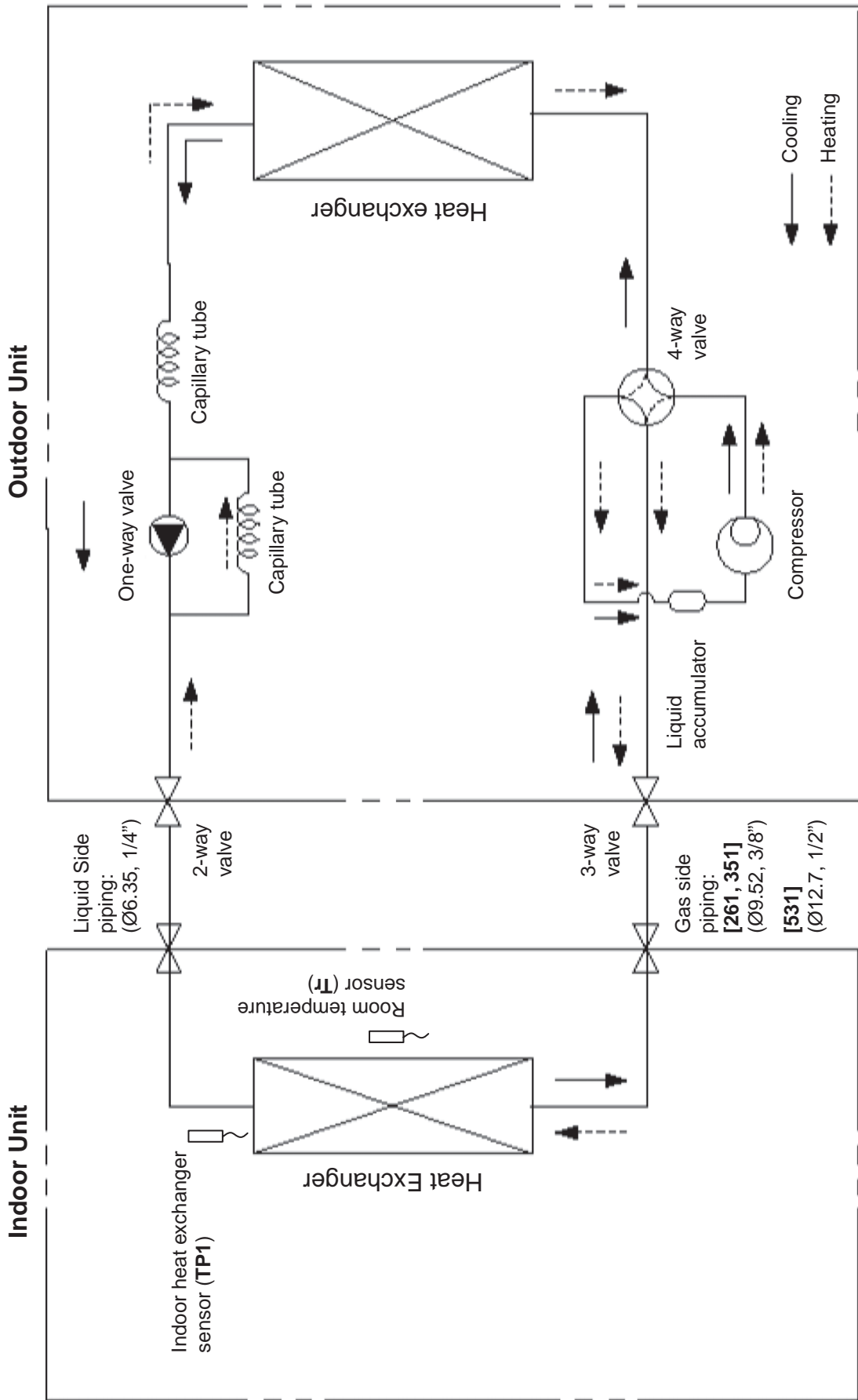

### 3. ELECTRICAL DATA

#### 3.1 WIRING DIAGRAMS

##### ■ Indoor Units HKED 261 G, HKED 351 G

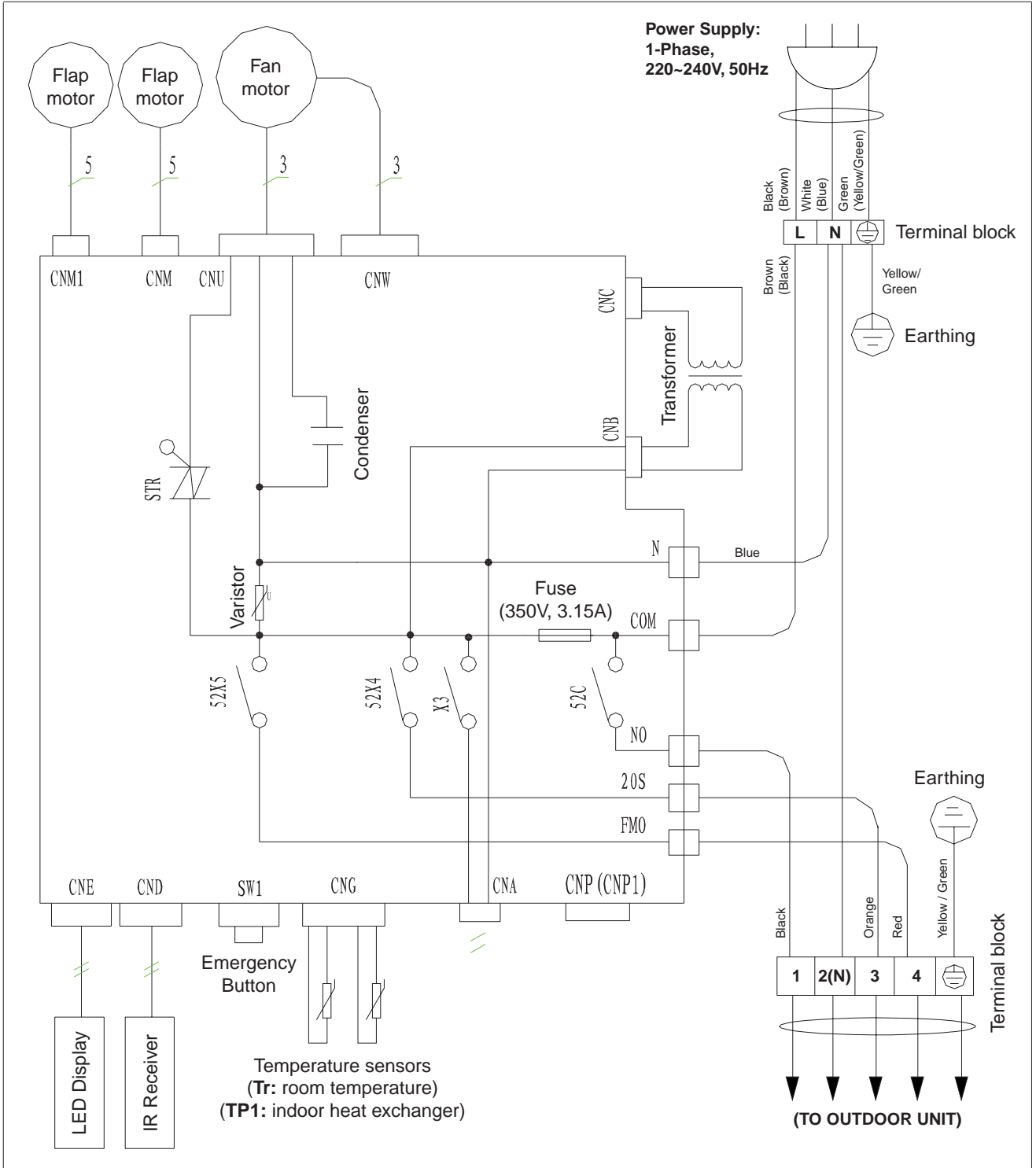

👉 **Min. recommended section of cables between Indoor and Outdoor Units:**  
 ○ Models HKED - HCND 351 G, 351 G: 1.5mm<sup>2</sup>.

■ Indoor Unit HKED 531 G

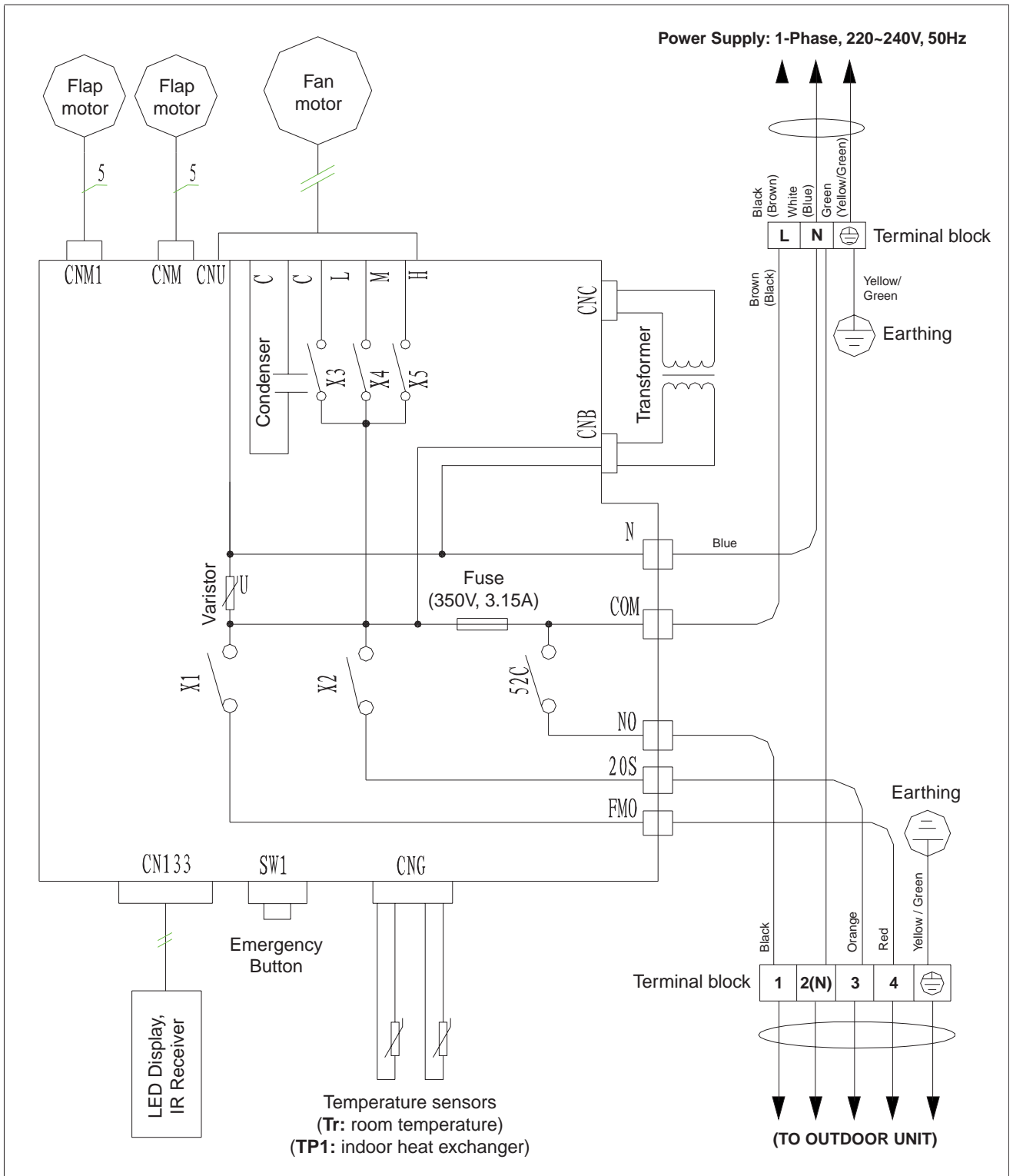

**🔧 Min. recommended section of cables between Indoor and Outdoor Units:**

○ Models HKED - HCND 531 G: 2.5mm<sup>2</sup>.

■ Outdoor Units HCND 261 G, HCND 351 G, HCND 531 G

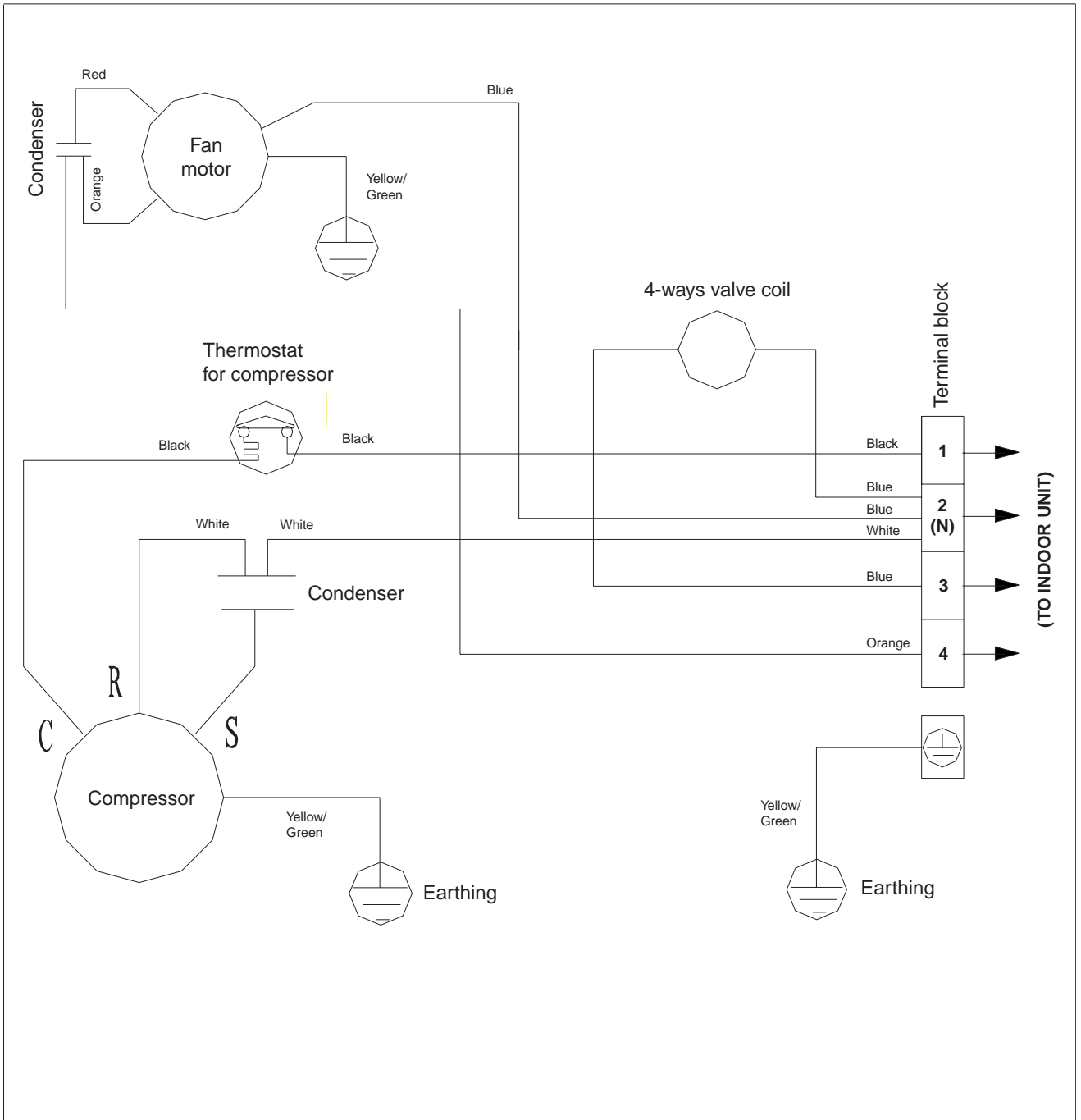

**🔧 Min. recommended section of cables between Indoor and Outdoor Units:**

- Models HKED - HCND 261, 351 G: 1.5mm<sup>2</sup>.
- Models HKED - HCND 531 G: 2.5mm<sup>2</sup>.

3.2 R/T FEATURES OF TEMPERATURE SENSORS

■ R-T diagram of thermistor resistance depending on temperatures

- Temperature sensor **Tr** (temperature detected inside the room)
- Temperature sensor **TP1** (temperatures on Indoor Unit's heat exchanger)

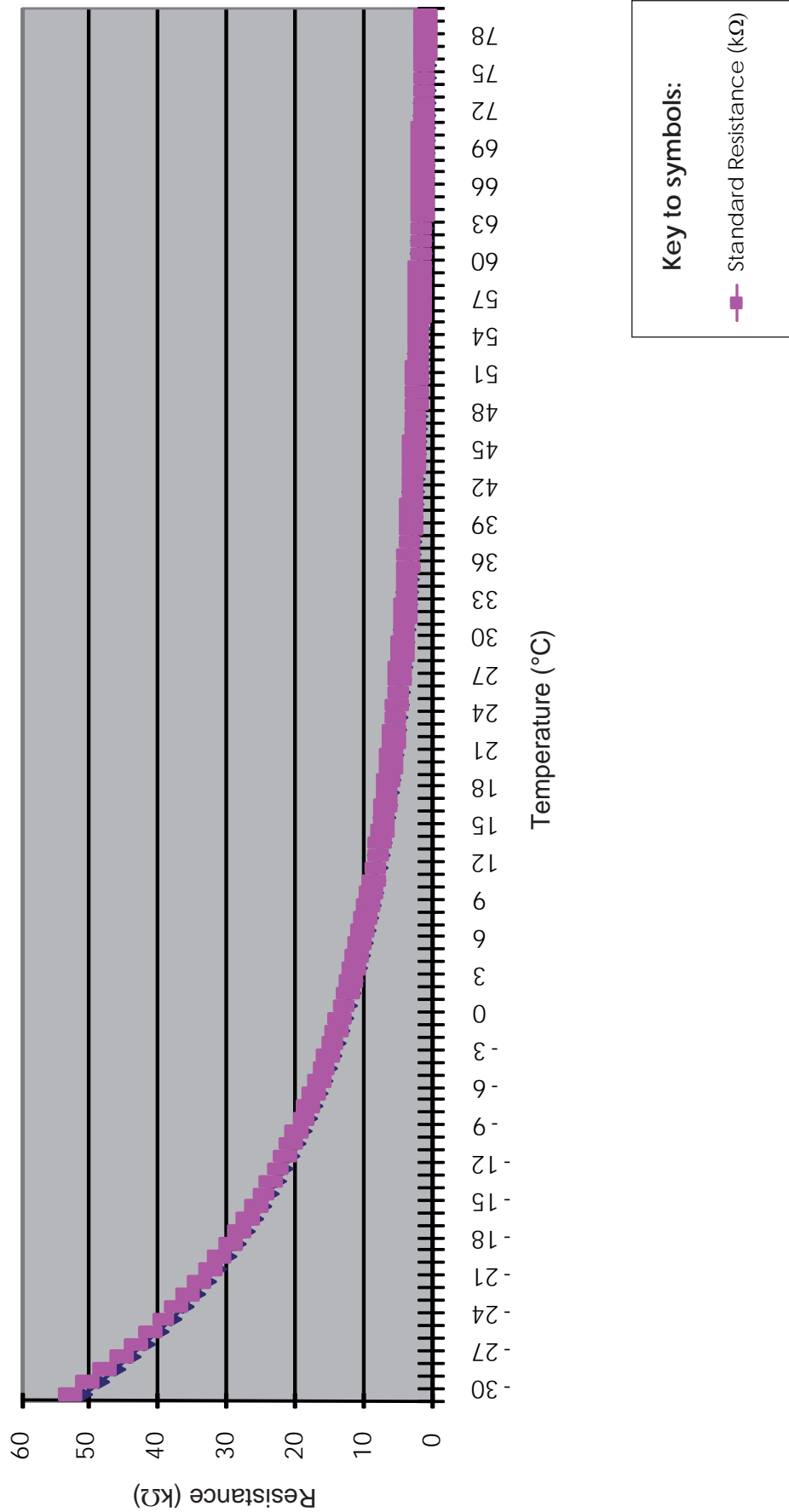

■ R-T table of thermistors resistance values depending on temperatures

○Tr (room temperature) | TP1 (Indoor Unit's heat exchanger temperature)

Temperature (°C)	Res. Min. (kΩ)	Standard (kΩ)	Res. Max. (kΩ)	Circuit voltage (5V, 4.3K)		Temperature (°C)	Res. Min. (kΩ)	Standard (kΩ)	Res. Max. (kΩ)	Circuit voltage (5V, 4.3K)	
				Down	Up					Down	Up
-30	51.195	52.840	54.521	0.38	4.62	26	4.771	4.821	4.871	2.36	2.64
-29	48.659	50.232	51.805	0.39	4.61	27	4.599	4.649	4.699	2.40	2.60
-28	46.299	47.772	49.248	0.41	4.59	28	4.434	4.485	4.535	2.45	2.55
-27	44.071	45.452	46.832	0.43	4.57	29	4.277	4.327	4.377	2.49	2.51
-26	41.968	43.261	44.554	0.45	4.55	30	4.126	4.176	4.226	2.54	2.46
-25	39.981	41.193	42.405	0.47	4.53	31	3.981	4.031	4.081	2.58	2.42
-24	38.102	39.238	40.375	0.49	4.51	32	3.842	3.892	3.942	2.62	2.38
-23	36.326	37.391	38.457	0.52	4.48	33	3.709	3.759	3.808	2.67	2.34
-22	34.646	35.645	36.645	0.54	4.46	34	3.581	3.631	3.680	2.71	2.29
-21	33.055	33.993	34.931	0.56	4.44	35	3.495	3.508	3.557	2.77	2.23
-20	31.550	32.430	34.310	0.59	4.41	36	3.340	3.389	3.438	2.80	2.20
-19	30.097	30.923	31.748	0.61	4.39	37	3.226	3.275	3.323	2.84	2.16
-18	28.722	29.497	30.271	0.64	4.36	38	3.117	3.165	3.213	2.88	2.12
-17	27.420	28.147	28.873	0.66	4.34	39	3.012	3.06	3.107	2.92	2.08
-16	26.186	26.868	27.55	0.69	4.31	40	2.912	2.959	3.006	2.96	2.04
-15	25.017	25.657	26.297	0.72	4.28	41	2.815	2.861	2.908	3.00	2.00
-14	23.908	24.509	25.11	0.75	4.25	42	2.722	2.768	2.814	3.04	1.96
-13	22.857	23.421	23.98	0.78	4.22	43	2.633	2.678	2.724	3.08	1.92
-12	21.859	22.389	22.918	0.81	4.19	44	2.547	2.529	2.637	3.12	1.88
-11	20.912	21.409	21.907	0.84	4.16	45	2.464	2.509	2.553	3.16	1.84
-10	20.013	20.48	20.917	0.87	4.13	46	2.385	2.429	2.473	3.20	1.80
-9	19.116	19.584	20.023	0.90	4.10	47	2.308	2.352	2.395	3.23	1.77
-8	18.322	18.734	19.146	0.93	4.07	48	2.235	2.278	2.231	3.27	1.73
-7	17.540	17.927	18.314	0.97	4.03	49	2.164	2.207	2.249	3.30	1.70
-6	16.797	17.160	17.524	1.00	4.00	50	2.096	2.138	2.180	3.34	1.66
-5	16.090	16.431	16.733	1.04	3.96	51	2.030	2.071	2.112	3.37	1.63
-4	15.418	15.739	16.060	1.07	3.93	52	1.966	2.006	2.047	3.41	1.59
-3	14.779	15.080	15.382	1.11	3.89	53	1.904	1.944	1.984	3.44	1.54
-2	14.170	14.454	14.737	1.15	3.85	54	1.844	1.884	1.923	3.48	1.52
-1	13.591	13.857	14.124	1.18	3.82	55	1.787	1.826	1.865	3.51	1.49
0	13.040	13.290	13.54	1.22	3.78	56	1.732	1.770	1.809	3.54	1.16
1	12.505	12.739	12.974	1.26	3.74	57	1.679	1.717	1.754	3.57	1.43
2	11.995	12.215	12.436	1.30	3.70	58	1.628	1.665	1.702	3.60	1.40
3	11.509	11.717	11.924	1.34	3.66	59	1.579	1.615	1.652	3.63	1.37
4	11.047	11.241	11.436	1.38	3.62	60	1.531	1.567	1.603	3.66	1.34
5	10.606	10.789	10.971	1.42	3.58	61	1.485	1.521	1.556	3.69	1.31
6	10.186	10.357	10.529	1.47	3.53	62	1.441	1.476	1.511	3.72	1.28
7	9.785	9.945	10.107	1.51	3.49	63	1.399	1.433	1.467	3.75	1.25
8	9.403	9.554	9.705	1.55	3.45	64	1.357	1.391	1.425	3.78	1.22
9	9.038	9.180	9.322	1.59	3.41	65	1.318	1.351	1.384	3.80	1.20
10	8.690	8.823	8.956	1.64	3.36	66	1.279	1.312	1.344	3.83	1.17
11	8.357	8.482	8.607	1.68	3.32	67	1.242	1.274	1.306	3.86	1.14
12	8.040	8.157	8.274	1.73	3.27	68	1.206	1.237	1.269	3.88	1.12
13	7.736	7.816	7.957	1.77	3.23	69	1.171	1.202	1.233	3.91	1.09
14	7.446	7.550	7.653	1.81	3.19	70	1.137	1.168	1.199	3.93	1.07
15	7.169	7.226	7.363	1.86	3.14	71	1.105	1.135	1.165	3.96	1.04
16	6.900	6.991	7.082	1.90	3.10	72	1.074	1.103	1.133	3.98	1.02
17	6.644	6.729	6.814	1.95	3.05	73	1.043	1.072	1.101	4.00	1.00
18	6.398	6.478	6.558	1.99	3.01	74	1.014	1.043	1.071	4.02	0.98
19	6.163	6.238	6.313	2.04	2.96	75	0.986	1.014	1.042	4.05	0.95
20	5.938	6.008	6.078	2.09	2.91	76	0.959	0.986	1.014	4.07	0.93
21	5.723	5.789	5.854	2.13	2.87	77	0.932	0.959	0.986	4.09	0.91
22	5.517	5.578	5.64	2.18	2.82	78	0.907	0.933	0.960	4.11	0.89
23	5.320	5.377	5.484	2.22	2.78	79	0.882	0.908	0.934	4.13	0.87
24	5.131	5.185	5.238	2.27	2.73	80	0.858	0.884	0.910	4.15	0.85
25	4.950	5	5.05	2.31	2.69	81					

## 4. CONTROL FUNCTIONS

### ■ Operation in "COOL" mode

#### 1. Condition for compressor ON.

If temperature which is detected inside the room (**Tr** sensor) is higher than set temperature **Ts** increased by 1°C, compressor starts. Therefore, the condition is the following:  $Tr > (Ts + 1)^\circ\text{C}$ .

#### 2. Condition for compressor OFF.

If temperature which is detected inside the room (**Tr** sensor) is equal of lower than set temperature **Ts** decreased by 1°C, compressor stops. Therefore, the condition is the following:  $Tr \leq (Ts - 1)^\circ\text{C}$ .

#### 3. Antifrost protection on Indoor Unit's heat exchanger.

If temperature on Indoor Unit's heat exchanger, detected by **TP1** sensor, is  $\leq 1^\circ\text{C}$  for 1 minute and compressor has been continuously operating for more than 10 minutes, Control PCB on Indoor Unit commands the stop of compressor and fan on Outdoor Unit, while Indoor Unit's fan works at "Low" speed.

The intervention of antifrost protection ends when temperature on Indoor Unit's heat exchanger, detected by **TP1** sensor, is  $\geq 7^\circ\text{C}$  and compressor has been stopped for more than 3 minutes. When the intervention of antifrost protection ends, compressor and fan on Outdoor Unit will be restarted and Indoor Unit's fan will rotate at set speed.

#### 4. Protection against too low temperature on Indoor Unit's heat exchanger.

If temperature on Indoor Unit's heat exchanger, detected by **TP1** sensor, is  $\leq -10^\circ\text{C}$  for 3 minutes and compressor has been working continuously for 3 minutes, Control PCB on Indoor Unit commands the stop of compressor, of Outdoor Unit's fan and of Indoor Unit's fan. Automatic swinging function of air outlet flaps will be stopped.

The intervention of protection will end 6 minutes later. However, if intervention condition described above occurs again within 6 minutes, Control PCB on Indoor Unit will command the stop of all devices, and the corresponding indication of malfunction will be displayed.

 For the description of Error Codes related to operating malfunctions inside autodiagnostic functions, please refer to "Section 6: Diagnostic & Maintenance" of this Technical Manual.

#### 5. Protection against insufficient performance in Cooling mode.

If after 5 minutes of compressor's operation, temperature on Indoor Unit's heat exchanger, detected by **TP1** sensor, is  $> 25^\circ\text{C}$  for 20 consecutive minutes, "Running" LED indicator  on Indoor Unit will flash for 4 times/6seconds or Error Code "E4" will be displayed.

If for further 20 consecutive minutes temperature on Indoor Unit's heat exchanger, detected by **TP1** sensor, is  $> 25^{\circ}\text{C}$ , Control PCB on Indoor Unit will command the stop of system as a result of the intervention of protection function for malfunction on Outdoor Unit, and "Running" LED  on Indoor Unit will flash again for 4 times/6seconds.

If during the second interval of 20 minutes temperature on Indoor Unit's heat exchanger, detected by **TP1** sensor, is  $< 25^{\circ}\text{C}$  or if compressor stops, Control PCB on Indoor Unit will command the restoration of normal display on Indoor Unit's Display and timer referred to 20 minutes' interval of monitoring will be reset when compressor restarts.

○Operation of system in Cooling mode can be represented by the following Diagram.

Diagram 1: Operation in Cooling mode

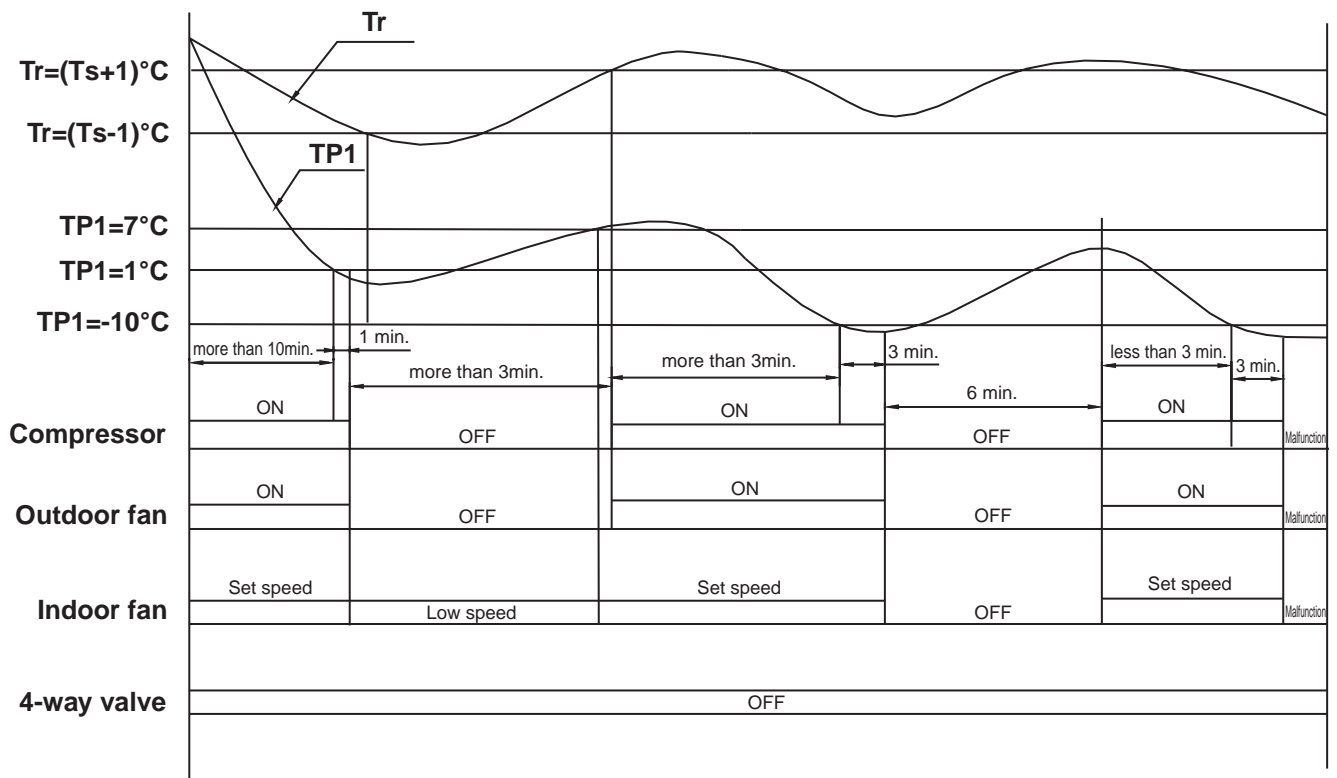

## ■ Operation in "HEAT" mode

### 1. Condition for compressor ON.

When temperature detected inside the room (**Tr** sensor) is lower than set temperature **Ts** reduced by 1°C, compressor starts. Therefore, the condition is the following:  $Tr < (Ts - 1)^\circ\text{C}$ .

### 2. Condition for compressor OFF.

When temperature detected inside the room (**Tr** sensor) is equal or higher than set temperature **Ts** increased by 3°C, compressor stops. Therefore, the condition is the following:  $Tr \geq (Ts + 1)^\circ\text{C}$ .

### 3. Anticold drafts' prevention at start.

When system operates in Heating mode, Indoor Unit's fan speed may be set to "High" speed, "Medium" speed, "Low" speed or "Auto" speed, by using IR remote control.

However, anticold drafts prevention function during start in Heating mode, has the priority as regards setting by IR remote control. This function consists in rotation control of Indoor Unit's fan, according to temperature detected on Indoor Unit's heat exchanger by **TP1** sensor.

If temperature on Indoor Unit's heat exchanger detected by **TP1** sensor is lower than 25°C, Indoor Unit's fan does not start.

If temperature on Indoor Unit's heat exchanger detected by **TP1** sensor is higher than 25°C but lower than 30°C, Indoor Unit's fan will rotate at "Ultra-Low" speed (or "Breeze", fan speed which cannot be selected by User through IR remote control).

If temperature on Indoor Unit's heat exchanger by **TP1** sensor is higher than 30°C but lower than 36°C, Indoor Unit's fan will rotate at "Low" speed.

As soon as temperature on Indoor Unit's heat exchanger detected by **TP1** sensor will be equal or higher than 36°C, Indoor Unit's fan will rotate according to the speed set by IR remote control.

○The intervention levels of anticold drafts prevention function during start in Heating Operation are shown in "Diagram 2: Operation in Heating mode", at the following page.

### 4. Protection against overheating of Indoor Unit's heat exchanger (thermal overload in Heating mode).

When, during Operation in Heating mode, temperature detected by **TP1** sensor on Indoor Unit's heat exchanger is  $\geq 56^\circ\text{C}$ , Outdoor Unit's fan is stopped by the intervention of thermal overload protection in Heating mode.

The intervention of protection ends as soon as temperature detected by **TP1** sensor on Indoor Unit's heat

exchanger is  $\leq 56^{\circ}\text{C}$ . When this conditions occurs, Outdoor Unit's fan may be started again.

A further intervention level of overload protection in Heating mode foresees that if temperature detected by **TP1** sensor is at least  $63^{\circ}\text{C}$ , forced stop of compressor and fan on Outdoor Unit is commanded, and after 2 minutes 4-way valve moves to OFF position. Rotation speed of Indoor Unit's fan will correspond to the speed set by IR remote control.

The intervention of this protection level will end after 6 minutes, as soon as normal operation (restart) of system will be restored in Heating mode. However, if within 10 minutes the required condition for the intervention of this protection level occurs, Control PCB on Indoor Unit will command the OFF all devices and the corresponding malfunction indication will be displayed.

○The levels of intervention of protection function against overload in Heating mode are shown in "Diagram 2: Operation in Heating mode" below.

Diagram 2: Operation in Heating mode

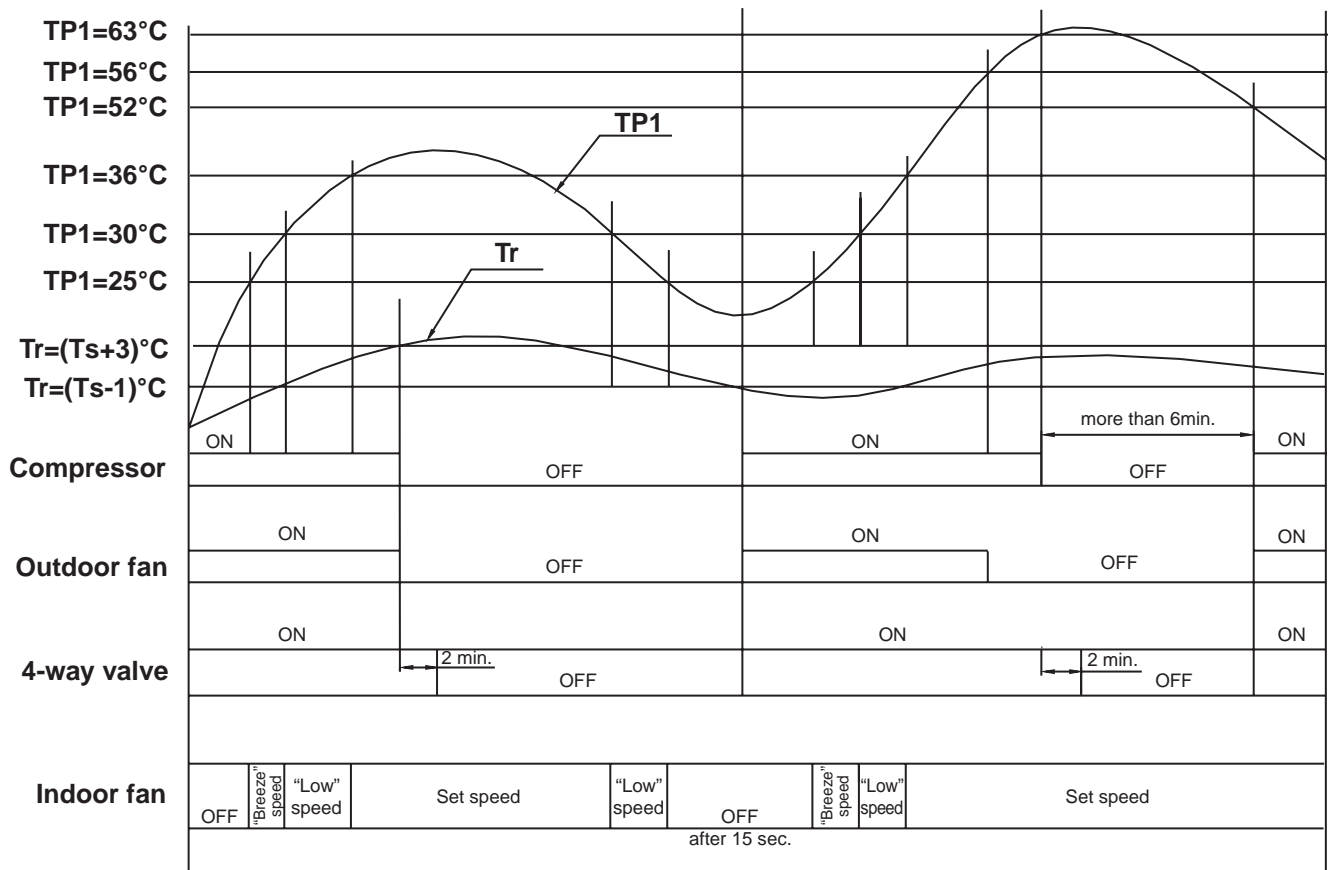

## 5. Protection for insufficient performance in Heating mode.

If after 5 minutes of compressor's operation, temperature on Indoor Unit's heat exchanger, detected by **TP1** sensor, is  $< 30^{\circ}\text{C}$  for 20 consecutive minutes, "Running" LED  on Indoor Unit will flash for 4 times/6seconds or Error Code "E4" will be displayed.

If for further 20 consecutive minutes temperature on Indoor Unit's heat exchanger, detected by **TP1** sensor,, is  $< 30^{\circ}\text{C}$ , Control PCB on Indoor Unit will command the stop of system as a result of the intervention of protection function for malfunction on Outdoor Unit and "Running" LED  on Indoor Unit will flash again for 4 times/6seconds.

○The intervention levels of protection function against insufficient performance in Heating mode are shown in "Diagram 2: Operation in Heating mode" at the previous page.

## 6. Automatic defrosting.

On these systems, the Outdoor Unit is not provided of a temperature sensor on heat exchanger, and it has no outdoor air temperature sensor. It follows that control electronics has to estimate the necessity to carry out automatic defrosting on the basis of hypothesis drawn by the analysis of other available parameters.

Control electronics estimates the necessity to carry out automatic defrosting according to time ( $T_{\text{vent. est.}}$  : variable, in this context, from 40 minutes to 120 minutes) of continuous operation of outdoor fan in Heating mode.

Automatic defrosting will have a basically longer duration as a direct function of value of  $T_{\text{vent. est.}}$  parameter, but it will be necessary to take into consideration another parameter.

In fact, control electronics estimates the necessity to carry out automatic defrosting also according to the decrease of heat pump's heating capacity, evaluated further to the variation (reduction) over the time ( $\Delta TP1$ : variable, in this context, from  $1^{\circ}\text{C}$  to  $5^{\circ}\text{C}$ ) of average temperature value on Indoor Unit's heat exchanger as regards the max. value ( $TP1_{\text{max}}$ ) of temperature itself. This max. value is detected after a sufficient time interval (about 7 minutes) is elapsed in Heating operation.

Automatic defrosting will have a basically longer duration, and it will occur more often as a direct function of value of  $\Delta TP1$  parameter.

In case of variation of Indoor Unit's rotating fan speed, when calculating  $\Delta TP1$ , the variation will be taken into consideration (positive in case of reduction in Indoor Unit's fan speed; negative in case of increase in Indoor Unit's fan speed) of **TP1** temperature deriving from this factor.

In brief, by considering the above parameters, automatic defrosting may have a duration variable from min. 4 minutes up to max. 8 minutes.

If, on the basis of above considered parameters, the presence of frost on Outdoor Unit's heat exchanger is supposed, automatic defrosting is started, with reversal of refrigerant cycle as regards operation in Heating mode.

During automatic defrosting, Outdoor Unit's fan and Indoor Unit's fan will be stopped, while 4-way valve moves to OFF position (position for operation in Cooling mode) and compressor will be started.

While automatic defrosting is in progress, LED Display on Indoor Unit will show "dF" indication.

On "Diagram 3: Automatic defrosting and operation of functional components" at the following page, it is described the corresponding operating sequence for each functional component of system.

**Diagram 3: Automatic defrosting and operation of functional components**

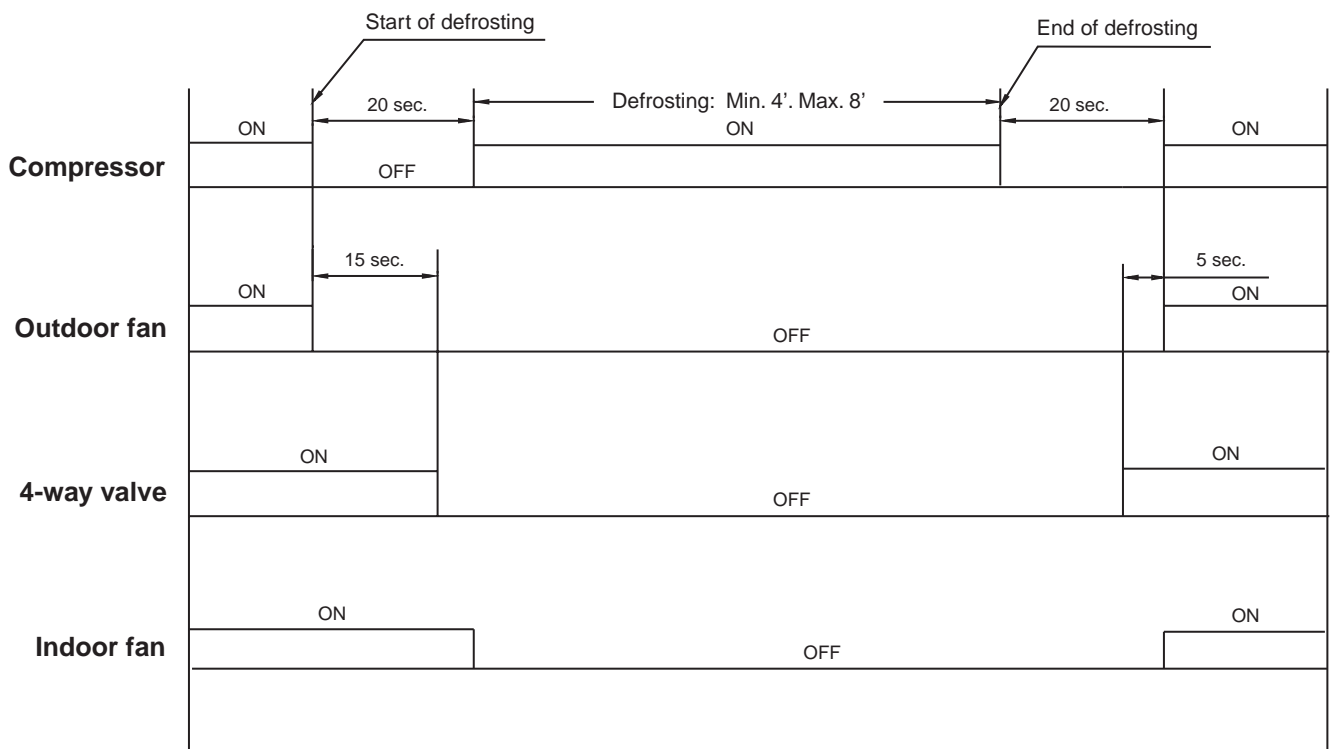

■ Operation in "DRY" mode

1. In this mode, the aim is above all to reduce humidity rate inside the room. Within this operating logic, the reduction in room temperature value represents an aim of minor importance, which in any case is reached within the limits of settings that cannot be modified by the User (see below), but the air volume treated by Indoor Unit results lower as regards operation in Cooling mode, for the reasons that are indicated at the following items.
2. Indoor Unit's fan speed is set to "Low" speed, and cannot be modified by the User through IR remote control.
3. Temperature (**Ts**) is automatically set to 25°C, and this value cannot be modified by the User through IR remote control.
4. The horizontal flap for air distribution is adjusted at a fixed position by control electronics, but this setting can be modified by the User by IR remote control.
5. Dry mode foresees the intermittent rotation of indoor fan, as it is shown in below "Diagram 4: Operation in Dry mode".

At start in Dry mode, before intermittent operation starts, indoor fan rotates for 20 seconds, so as to allow the survey of room temperature value (**Tr**).

Diagram 4: Operation in Dry mode

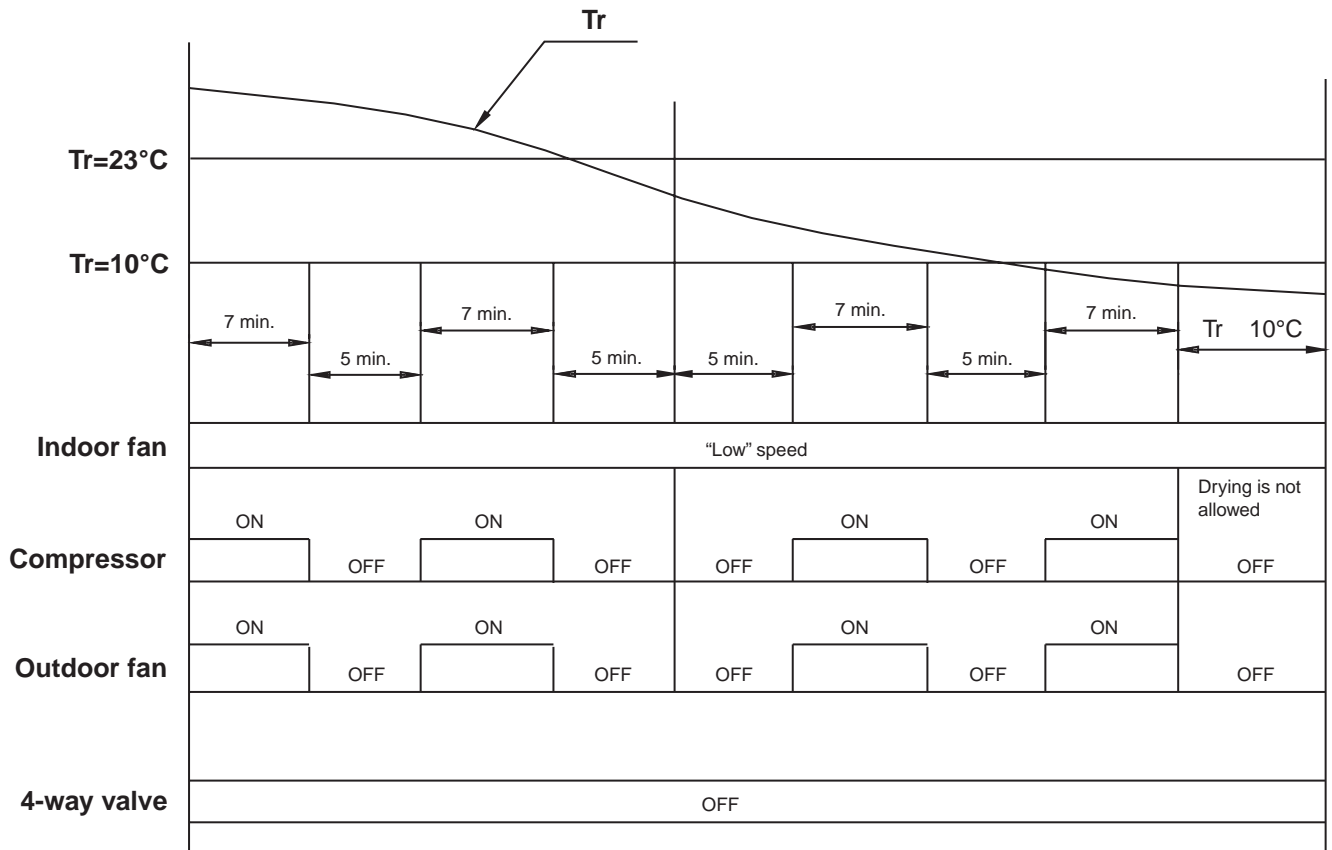

■ Operation in "FAN" mode

1. In this operation mode, compressor, Outdoor Unit's fan and 4-way valve are OFF.
2. Rotation speed of Indoor Unit's fan can be freely selected, by using IR remote control and selecting among the following available options: "High", "Medium", "Low".
3. If operation in Fan mode is commanded by control electronics when selecting "AUTO" mode, the first selection in Fan mode will be kept also if system is stopped and then restarted, within a max. room temperature variation of  $\pm 1^\circ\text{C}$  ( $T_r$ ) as regards set temperature ( $T_s$ ).

Diagram 5: Operation in Fan mode

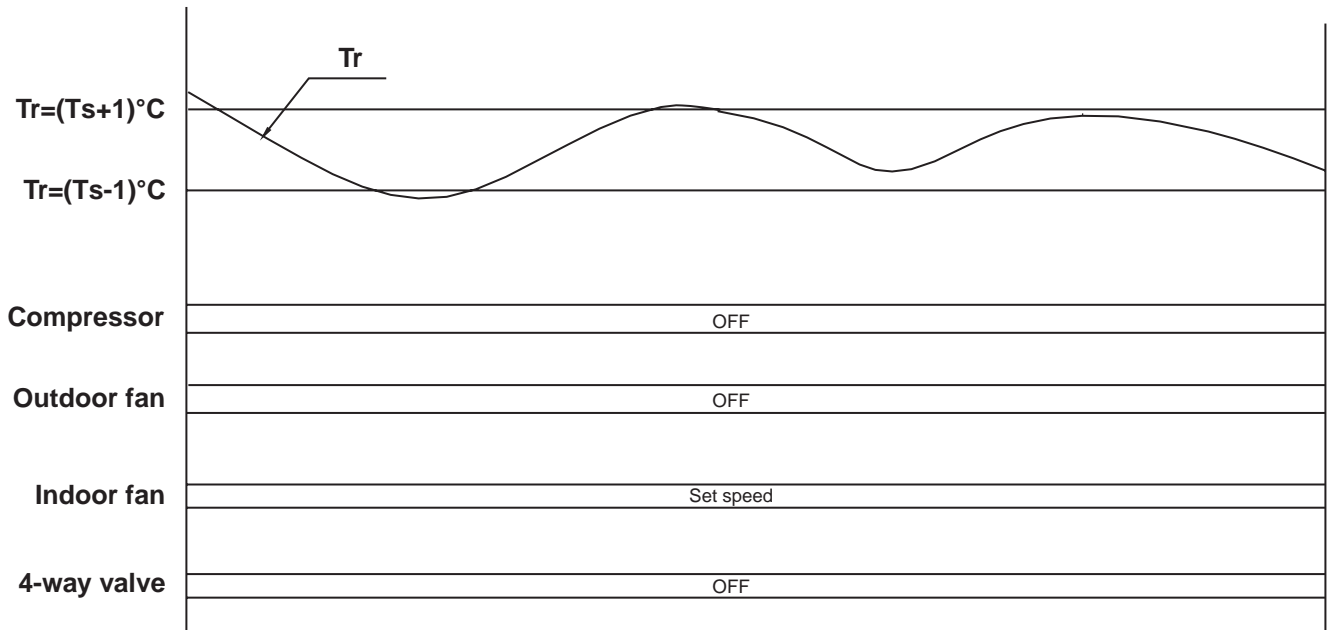

■ **Operation in "AUTO" mode**

1. This operation mode can be selected by the User when starting the system by IR remote control, or it is selected by control electronics if Emergency Button on Indoor Unit is pressed.
2. Default setting of temperature value (**Ts**) in this operation mode is of 25°C, and this value cannot be modified by the User.
3. At start in "AUTO" mode, the system's control electronics will select among operation in Heating mode, in Fan mode or in Cooling mode according to the detected room temperature value (**Tr**).

If room temperature is equal or lower than 21°C, operation in "HEAT" mode will be selected.

If room temperature is higher than 21°C but lower than 26°C, operation in "FAN" mode will be selected.

If room temperature is higher than 26°C, operation in "COOL" mode will be selected.

○ This is represented in below "Diagram 6: Selection of operation mode in "AUTO" mode".

This selection keeps effective until the system is stopped, regardless of next evolution of **Tr**.

4. Indoor fan speed may get modified freely, by selecting among available speeds.
5. It is possible to adjust the direction of supplied airflow, both in horizontal and in vertical direction.

Diagram 6: Selection of operation mode in "AUTO" mode

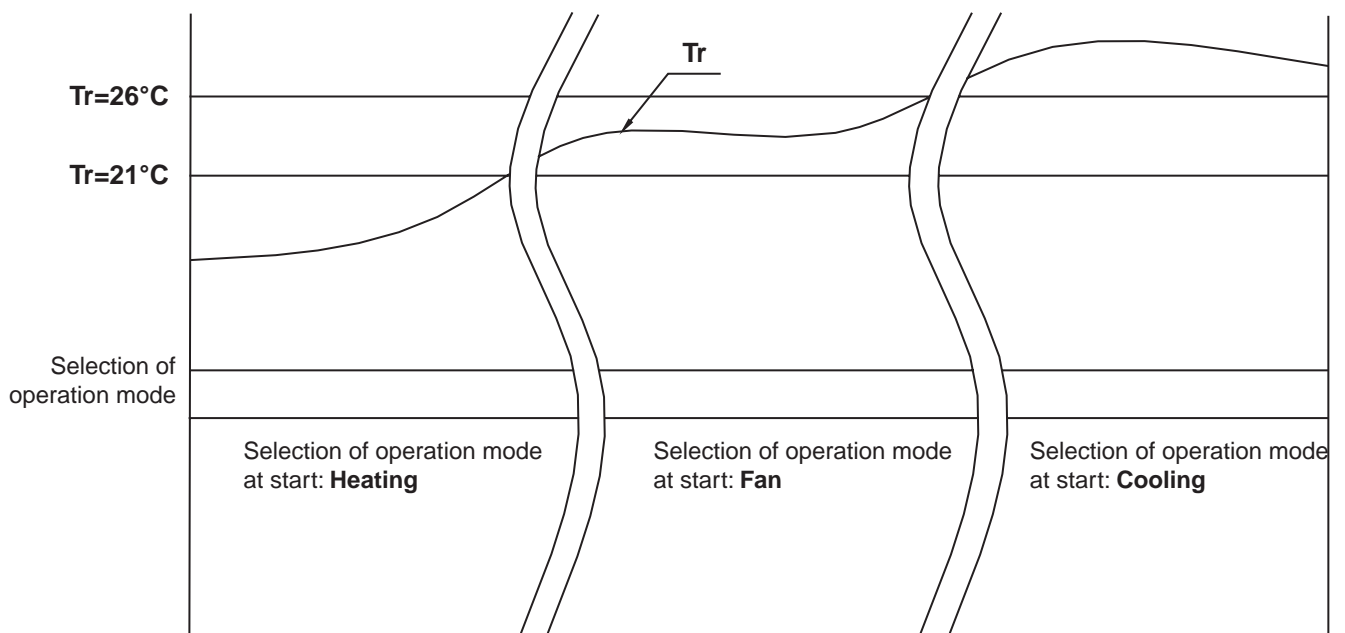

**Note:** The default - not modifiable - setting of temperature value (**Ts**) is 25°C.

**■ "Timer On" / "Timer Off"****"Timer On"**

1. When the system is powered but not operating (standby), it is possible to set the automatic start of the appliance, by using IR remote control.
2. Press "TIMER" button on remote control.
3. If the system is in standby, "Timer On" function will be selected (postponed automatic start).

Each time "TIMER" button is pressed, the programmed time interval for automatic start of air conditioner will be increased by 1 hour, up to max. 24 hours.

On Indoor Unit's frontal panel, "Timer" LED indicator will light up  (of orange colour) and on 2-digits LED Display on Indoor Unit, set time interval (in hours) for automatic start of system will be displayed. The same time interval (in hours) will be displayed also on LCD Display on IR remote control.

If set interval is of 24 hours, a further press on "TIMER" button will cancel Timer setting, and all corresponding indications both on Indoor Unit and on IR remote control will go out.

4. "Timer On" function operates according to a simple time meter, therefore it is not possible to carry out a real time setting (start at ...h), but a setting according to a time interval.

As time passes by, the indication referred to the remaining time interval before the system's start will be decreased by 1 hour's steps.

As soon as all set time interval has elapsed, the system will start according to operating parameters which were selected when "Timer On" was set. At the same time, each indication referred to the setting itself will disappear from Indoor Unit's LED Display and from IR remote control's LCD Display.

5. On these systems, it is not possible to programme the start followed by the stop or vice versa, therefore at the end of time interval set by "Timer On" function, the system will keep on operating till the User stops it by IR remote control.

**"Timer Off"**

1. When the system is ON, it is possible to programme the automatic stop of the appliance, by using IR remote control.
2. Press "TIMER" button on remote control.
3. If the system is ON, "Timer Off" (postponed automatic stop) will be selected.

At each subsequent press on "TIMER" button, time interval set for automatic stop will be increased by 1 hour, up to max. 24 hours.

On Indoor Unit's frontal panel, "Timer" LED indicator  (of orange colour) and on 2-digits LED Display on Indoor Unit, set time interval (in hours) for automatic stop of system will be displayed. The same time interval (in hours) will be displayed also on IR remote control's LCD Display.

If set interval is of 24 hours, a further press on "TIMER" button will cancel Timer setting and all corresponding indications both on Indoor Unit and on IR remote control will go out.

**4.** "Timer Off" function operates according to a simple time meter, therefore it is not possible to carry out a real time setting (stop at ...h), but a setting according to a time interval.

As time passes by, the indication referred to the remaining time interval before the system's stop will be decreased by 1 hours' steps.

As soon as all set time interval has elapsed, the system will stop. At the same time, each indication referred to the setting itself will disappear from Indoor Unit's LED Display and from IR remote control's LCD Display.

**5.** On these systems, it is not possible to programme the stop followed by the start or vice versa, therefore at the end of time interval set by "Timer Off" function, the system will remain OFF until the User restarts it by using IR remote control.

**■ "SLEEP" operation**

1. This function is available in the following operation modes: "COOL" and "HEAT".
2. "SLEEP" function foresees also the rotation of Indoor Unit's fan at fixed Low speed, therefore it allows to reduce operating sound level of Indoor Unit.
3. "SLEEP" function can be started up by pressing the special "SLEEP" button on IR remote control. On LCD Display of remote control, "SLEEP" indicator will light up.
4. "SLEEP" operation in Cooling mode.

Set temperature is gradually increased up to max. 2°C as regards starting value set by remote control when selecting "SLEEP" function.

○ This gradually reduces comfort, but also allows to decrease power consumption. The reduced sound level allows you to rest, or to devote yourself to activities that require a silent environment.

5. "SLEEP" operation in Heating mode.

Set temperature is gradually decreased up to max. 5°C as regards starting value set by remote control when selecting "SLEEP" function.

○ This gradually reduces comfort, but also allows to decrease power consumption. The reduced sound level allows you to rest, or to devote yourself to activities that require a silent environment.

6. To cancel "SLEEP" function, press again "SLEEP" button on remote control, or stop the system by IR remote control.

**■ Operation with Emergency Button**

1. If you press Emergency Button placed under Indoor Unit's frontal panel, it is possible to start temporarily the system without using IR remote control. This selection is compulsory if remote control's batteries are exhausted and there is no possibility to immediately replace them, or when remote control itself is malfunctioning or not available.
2. If you press Emergency Button when the system is powered but OFF, Emergency operation in "AUTO Mode" will be started up and the air conditioner will operate in the most suitable mode according to room temperature conditions, at set temperature of 25°C.

In order to stop Emergency operation, it is sufficient to press ON/OFF button on remote control, or press once again Emergency Button on Indoor Unit.

3. For all details about operation in "AUTO Mode", please refer to page **FU-9** of this Technical Manual..

### ■ "Auto-Restart" function after a blackout

1. As we have already seen previously, (see "Section 1: General Information" of this Technical Manual), normally the system is able to restart automatically with previously settings before blackout occurred. Therefore, there is no need to use IR remote control.

Before system is restarted, it is necessary to wait for 3 minutes since power is restored.

○ However, if operating data memory is accidentally cancelled - this possibility is uncommon, but also possible - the system will not automatically restart and it will be necessary to press ON/OFF button on remote control to restore the appliance's operation.

2. However, if "TIMER" function had been previously set, it will be cancelled and will need to be set again by the User.

"SLEEP" function too must be expressly set again by the User.

If "SWING" and/or "AIR FLOW" functions (see above) were working when blackout occurred, they must be expressly selected by the User.

### ■ "Self-Check" (quick autodiagnosis of malfunctions)

You may reach this diagnostic mode by powering the system through main power switch, and at the same time by keeping pressed the Emergency Button on Indoor Unit.

All indicators on Indoor Unit's LED Display will light up in sequence and then will go out, if control electronics do not detect any malfunction. On the contrary, the Error Code ("E\_") will be shown, and at the same time LED "Running" indicator  on Indoor Unit's frontal panel will flash according to the codification corresponding to the detected malfunction (see "Section 6: Diagnostic & Maintenance" of this Technical Manual).

### ■ Advanced functions for malfunction diagnosis

In case of eventual operation malfunctions on system, most common malfunctions among them will be indicated by special "Error Codes" that will be shown on Indoor Unit's LED Display, and by codified flashing of "Running" LED indicator , placed on Indoor Unit's frontal panel.

This allows targeted and so quicklier interventions for resolution of eventual malfunctions.

For the list of "Error Codes", the description of corresponding malfunctions and procedures, and checks for malfunctions' resolution, please consult "Section 6: Diagnostic & Maintenance" of this Technical Manual.

## 5. INSTALLATION

All steps of installation must be carried out according to National and local laws and rules. The following directions do not meet all possible circumstances of installation. For more information or in case of particular problems, please contact the local Distributor.

### SAFETY PRECAUTIONS

Please read carefully the following "Safety Precautions" first then accurately execute the installation work.

The precautionary points indicated herein are divided under two headings, "WARNING" and "CAUTION". If you do not observe what is indicated in "WARNING" you may have dramatic consequences such as death or serious injuries. In the same way, there is also a possibility of serious consequences in relationship to the points listed in the "CAUTION" section as well. In either case, important safety related information is indicated, so by all means, properly observe all that is mentioned.

After completing the installation, along with confirming that no abnormalities were seen from the operation tests, please explain operating methods as well as maintenance methods to the User of this equipment, based on the Owner's Manual. Moreover, ask the Customer to keep this sheet together with the Owner's Manual.



### WARNING

- This system should be applied to places as households, residences and the like. Application to other environment such as engineering shop could cause equipment malfunction.
- Please entrust installation to either the Company which sold you the equipment or to a professional Installer. Defects from improper installations can be the cause of water leakage, electric shocks and fires.
- Execute the installation accurately, based on following the Installation instructions. Again, improper installations can result in water leakage, electric shocks and fires.
- If an air-conditioning system of high capacity is installed in a small room, it is needed to take the necessary countermeasures to face up to the rare event that in case of refrigerant leakages, the gas concentration exceeds the threshold value. In this rare possibility, there is a risk of lack of oxygen. In order to prepare the suitable countermeasures, please call the Distributor who sold you the air conditioner.
- If during the Indoor Unit's installation work the refrigerant gas leaks, it is necessary to immediately ventilate the room, as if the gas gets in contact with a heating source or fire, it becomes toxic.  
Confirm after the installation work that refrigerant does not leak. If coming in contact with fire or heating sources (a fan heater, a stove or movable cooking stove, etc.), refrigerant leaking in the room could generate toxic gas.
- For installation, confirm that the installation site can sufficiently support heavy weight. When strength is insufficient, injury can result from a falling of the Units.
- For electrical work, please check that a licensed Electrician executes the work while following the safety standards related to electrical equipment, and local regulations as well as the installation instructions, and that only exclusive use circuits are used. Insufficient power source circuit capacity and defective instalment execution can be the cause of electric shocks and fires.
- Accurately connect wiring by using the proper cable, and ensure that the external force of the cable is not conducted to the terminal connection part, through properly securing it; improper connection or securing can result in heat generation or fire.  
Take care to insert the electrical cables into the electric box by the bottom side (so as to avoid water that may reach the cable to enter the electric box), and accurately install the special service cover on the Unit's panel.
- Improper installation can result in heat generation or fire.  
When setting up or moving the location of the air conditioner, do not mix air or anything other than the designated refrigerant (R410A) within the refrigerating cycle. If air enters the refrigerating circuit, compressor may break down or it may occur malfunctions and/or abnormal high pressure.
- For the installation, always use accessories and components authorized by the Manufacturer. If using unauthorized parts, this may result in water leaks, electric shocks, fire and/or refrigerant leaks.

**CAUTION**

- Execute proper grounding. Do not connect the ground wire to a gas pipe, water pipe, lighting rod or telephone ground wire. Improper placement of ground wires can result in electric shock.
- The installation of an earth leakage breaker is necessary. Not installing an earth breaker may result in electric shock.
- Do not install Units where there is a hazard about leakage of combustible gas. The rare event of leaked gas collecting around Units could result in explosion or fire.
- For the drain pipe, follow the installation instructions to ensure that it allows proper drainage. It is very important to insulate the first section (about 1 metre) of the drain hose on Indoor Unit to prevent condensation outside the piping. Inadequate discharge piping can result in water leakage and/or damages on installation site.

**PRECAUTIONS TO TAKE WHEN INSTALLING R410A AIR CONDITIONERS**









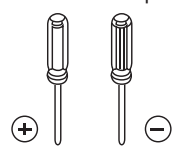

- All the fixtures used for installing and checking the refrigerant system (gauge manifold, service hoses, and so on) must be expressly designed for this kind of appliances (see further on).
- As the vapor pressure of R410A refrigerant is about 1.6 times higher than R22 refrigerant at the same temperature, you need to use refrigerant copper pipes having a sufficient thickness (at least 0.8mm), depending on piping's diameter.
- Never use the same fixtures that are used on systems adopting R22 refrigerant. This is due to the fact that systems adopting R410A refrigerant do not tolerate infiltrations of mineral refrigerant oil deriving from circuit with R22. That above except for vacuum pump, provided that a one-way valve has been added to the vacuum pump. This one-way valve must be able to operate in case of accidental turn off of the vacuum pump itself (i.e.: blackout) during air purge operations.
- In particular, the gauge manifold, the service hoses, the torque wrench (for tightening of flare connections having 1/2" and 5/8" diameters), the flaring tool and the refrigerant cylinder must be exclusively designed for R410A refrigerant.
- Moreover, the electronic gas leakage detector must be exclusive for HFC refrigerant (high sensitiveness type) so the same device as for R407C refrigerant can be used.
- All the operation of refrigerant charging must be carried out with R410A refrigerant in liquid phase. For this purpose, an electronic balance and a refrigerant cylinder with suction from its bottom are necessary. In this way, the exact amount of refrigerant in liquid phase can be charged from the bottom of charging cylinder.
- The liquid phase of refrigerant drawn from the cylinder for the above mentioned operations must be over 90% (in weight percentage) compared to the gaseous phase.
- In case of considerable refrigerant leakage from the system, avoid to do partial topping up, because the exact amount of refrigerant left inside the air conditioner's circuit will remain unknown, definitely leading to excessive or insufficient refrigerant charge.  
As R410 refrigerant is a binary mixture of R32 and R125, refrigerant leakage in gaseous phase may change slightly ratio between the two components, **nevertheless this does not remarkably modify the working conditions inside refrigerant circuit.**
- In case of leakages of R410A refrigerant, it is strongly recommended to discharge - of course by recovering it - all refrigerant, and to perform all necessary steps for a new charge of refrigerant, complete and weighed out according to indications on Outdoor Unit's label, after vacuum operation.

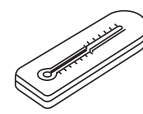

**5.1 CHECKS AND PRELIMINARY OPERATIONS**

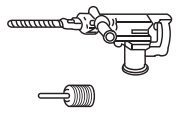

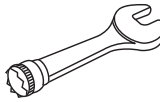
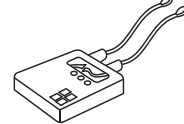
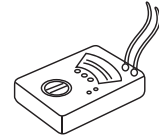

○ Before starting the installation work, be sure to have all necessary tools and materials for carrying out all different phases of procedures.

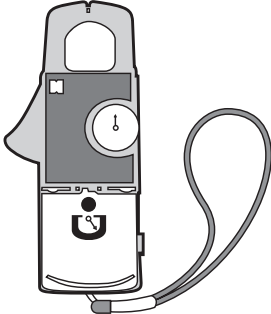
○ Check if there are all accessories sold together with Units, and then buy on site all necessary accessories and components which are not sold with the appliance.

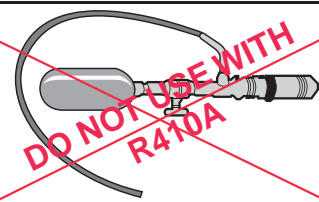
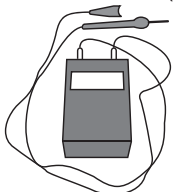
**■ Tools and components necessary for installation (not exhaustive list):**

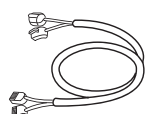
<p><b>Screw drivers</b> (flat and cross-shaped)</p>  <p>Assembly and disassembly.</p>	<p><b>Drill</b></p>  <p>Making holes for fixation plugs.</p>	<p><b>Tape measure</b></p>  <p><b>Cutter</b></p>  <p>Metre: for measuring length/distance Cutter: cutting of plastic bands.</p>	<p><b>Gas leakage detector for R410 and liquid soap</b></p>  <p>Check of gas leakages.</p>	<p><b>Thermometer</b></p>  <p>Inlet and outlet temperature on Indoor Unit.</p>	<p><b>Allen keys</b> (4 and 5mm)</p>  <p>Opening and closing of service valves.</p>
<p><b>Wall cutter</b> (65mm diameter)</p>  <p>Making holes into the wall.</p>	<p><b>Fork wrench and adjustable spanner</b></p>  <p>Connection tightening.</p>	<p><b>Torque wrench</b></p>  <p>Pipe connection tightening.</p>	<p><b>Digital or analogue multimeter</b></p>  <p>For measuring resistance, voltage and current.</p>	<p><b>Isolation resistance meter</b></p>  <p>Prevention of electric shocks.</p>	<p><b>Roller pipe cutter</b></p>  <p><b>Deburring tool</b></p>  <p>For cutting of pipings. For deburring of rims.</p>

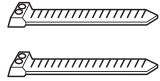
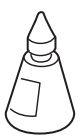
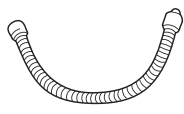
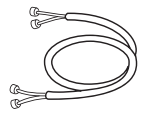
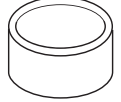
<p><b>Amperometric pliers</b></p> 	<p><b>Spirit level</b></p> 	<p><b>Thermometric sensor</b></p> 
	<p><del><b>Gas leak detector lamp</b></del></p> 	<p><b>Digital multimeter (Tester)</b></p> 

<p><b>Electrical cables</b></p>  <p>Wiring between Units.</p>	<p><b>Protection cover</b></p>  <p>For covering O.U. (when it is not used)</p>	<p><b>Rubber pads</b></p>  <p>Absorption of vibrations (O. U.).</p>	<p><b>Pipe clips</b></p>  <p>Fixing of cables and pipes.</p>	<p><b>Adhesive</b></p>  <p>Finishing.</p>	<p><b>Flexible drain hose</b></p>  <p>For draining condensate.</p>
<p><b>Refrigerant pipings</b></p>  <p>Piping connections between Units.</p>	<p><b>Putty</b></p>  <p>Finishing of wall hole (I.U. side)</p>	<p><b>Vinyl adhesive tape</b></p>  <p>For taping cables and pipings.</p>	<p><b>IR Remote Control</b></p>  <p><b>For Models HKED 261, 351, 531 G</b></p>		

■ **R410A Refrigerant Specifications**

Working pressures of R410A refrigerant are about 1.6 times higher than those of R22 refrigerant. For systems with R410A, it is required the use of compressors having polyester synthetic lubrication oil (POE). Mineral lubrication oil is not compatible with refrigerant circuits with R410A.

Refrigerant	R22 (pure)	R410A (mixture)	R407C (mixture)
Refrigerant oil	Mineral oil (SONTEX 200L)	Synthetic oil (POE)	Synthetic oil (POE)
Pressures	Factor: "1"	Factor: 1.6 as regards R22	Factor: 1.1 as regards R22

■ **Sequence (purely as an indication) of installation work**

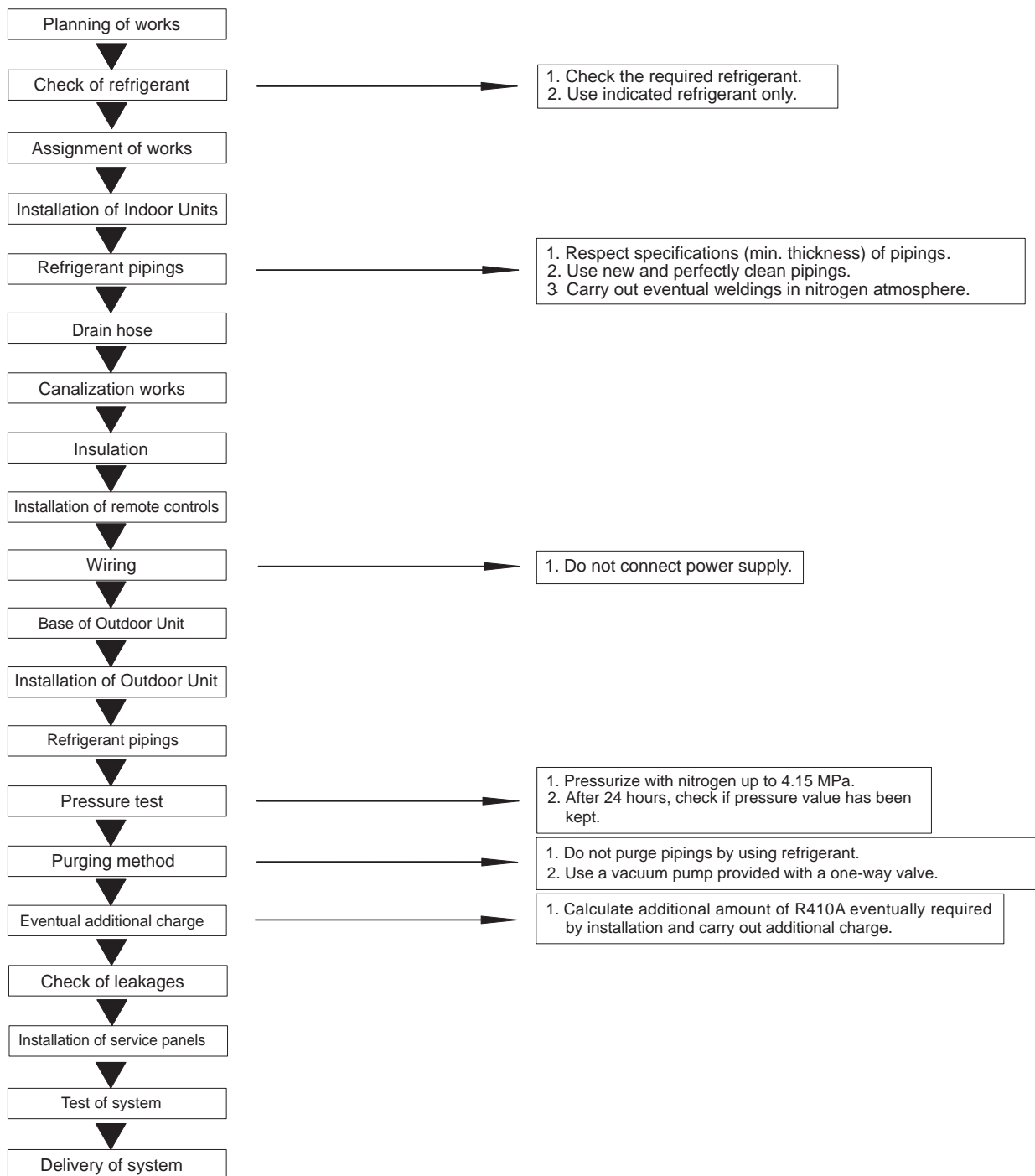

■ Refrigerant pipings

1. Use refrigerant pipings and materials designed for R410A refrigerant.
2. For min. thickness of refrigerant pipings, refer to the following table.

Pipings' diameter	Φ 6.35mm	Φ 9.52mm	Φ12.7mm	Φ15.88mm	Φ19.05mm
Min. thickness (mm)	0.8	0.8	0.8	1.0	1.2

☞ **Note:** Carry out installation of refrigerant pipings in full observance of current regulations.

■ Tools

○The star (\*) indicates tools that have been designed for R410A refrigerant specifically. Please keep these tools separately from those that are currently used for other kind of refrigerant.

Tool	Specific use of tool	
Roller pipe cutter	Cutting of refrigerant pipings.	Refrigerant pipings connections.
*Flare tool	Piping flaring.	
*Torque wrench	Piping connection tightening.	
Countersink (weldings only)	Expansion ("sockets") of pipings.	
Tube bender	Bending of pipings.	
Nitrogen cylinder (gas)	For welding without oxidation.	Connections' seal.
Cylinders and torch	Braze welding.	
*Gaugemanifold	Vacuum operations and refrigerant charge.	Pressure test. Additional charge of R410A refrigerant.
*Service pipings (so-called "whips")		
*Vacuum pump (with one-way valve)		Elimination of air and humidity left over in refrigerant pipings.
Electronic balance		Additional charge: with R410A refrigerant.
*Electronic gas leak detector	Specific for HFC. Check of leakages.	

■ Useful suggestions

- Check of refrigerant required by system.** Before starting installation, check which refrigerant (R410A) is required by system, and get ready the materials and tools specific for refrigerant itself.
- Refrigerant pipings.** Respect usual precautions for a professional installation of pipings, in order to prevent any possible malfunction of system. If weldings are required, take care of making them in nitrogen atmosphere, in order to prevent any oxidation inside the pipings, near welding points.
- Pressure test.** Keep the system under pressure (4.15 MPa) with nitrogen for about 24 hours so as to make sure that refrigerant connections have a satisfactory seal.
- Vacuum operation.** Install a one-way valve on vacuum pump, in case this device is not already foreseen on the pump itself.
- Additional charge.** Calculate the eventual additional amount of R410A, and add refrigerant in correct way, by using an electronic precision balance and specific service pipings.

## 5.2 INSTALLATION OF INDOOR UNITS HKED 261, 351, 531 G

○Before starting the air conditioner, please read carefully the information in this "USER'S MANUAL". The User's Manual contains very important suggestions related to installation, operation and maintenance of the air conditioner and concerning your personal safety.

○**The Manufacturer accept no responsibility for the damages that may arise due to non-observance of the instructions listed in this "USER'S MANUAL".**

### ■ Disposal of an old air conditioner

○Before disposing an old air conditioner, please make sure it is inoperative and carry out the disposal by adopting all safety precautions. Unplug it from the power line in order to avoid risks of electric shock.

○Please remember that an air conditioner contains refrigerant fluid, requiring specialized waste disposal.

○The valuable materials contained in the air conditioner can be recycled. Contact your local Waste Disposal Center for adequate disposal or contact your Dealer for any question.

○Please make sure that piping of your air conditioner does not get damaged before being picked up by the relevant Waste Disposal Center. You can contribute to the protection of the environment by adopting an appropriate anti-pollution method of disposal.

### ■ Disposal of the packaging of your new air conditioner

○All the packaging materials used in the package of your new air conditioner can be disposed without any danger for the environment.

○The cardboard may be broken or cut into small pieces and given to a Waste Paper Disposal Service. The wrapping bag made of polyethylene and the polyethylene foam pads contain no fluorochloric hydrocarbon.

○All these valuable materials may be taken to a Waste Collecting Center and used again after adequate recycling.

○Consult your local Authorities for the name and address of the Waste Materials Collecting Centers and Waste Paper Disposal Services nearest to your house.

### ■ General warnings for safety

○Do not operate damaged air conditioners. In case of doubt, contact your Dealer.

○Use of air conditioner must be carried out in strict compliance with the instructions listed further on.

○Do not damage any parts of the air conditioner that carry refrigerant by piercing or perforating the piping with sharp or pointed objects, by crushing or twisting the tubes or scraping off the surfaces' coatings. If the refrigerant spurts out and gets into eyes, this may result in serious injuries.

○Do not obstruct or cover the ventilation grille of the air conditioner. Do not put fingers nor insert objects into the inlet/outlet vent or into the motorized louver.

○Do not allow children to play with the air conditioner. Children should be never allowed to sit on the Outdoor Unit.

○The appliance is not intended for children and disabled people. They must not operate the air conditioner without supervision.

○Electrical works must be carried out according to the local laws. If the power cable is damaged, it must be replaced by the Manufacturer or by qualified Personnel. Size of power cables and connecting wires must be adequate to the characteristics of the air conditioner (current values and power input values).

○If fuses on the PCB are blown, they must be replaced with new fuses of the same type and size.

○After installation, power plug should be properly disposed.

○Exhausted batteries (infrared remote controller) should be properly disposed.

○Always remember to unplug the air conditioner before opening the inlet grille. Never try to unplug the air conditioner by pulling off the power cable. Always grip the power plug firmly and pull it straight out of the power socket.

- **Strictly observe the instructions provided in this Technical Manual.**
- **The air conditioning system contains inside its circuit a refrigerant gas (R410A) under pressure. Never disconnect for any reason refrigerant pipings before recovering refrigerant first.**
- **Never perform any improper handling on Outdoor Unit's service valves or on Indoor Unit's pipe unions.**
- **Invite the Customer to keep User's Manual within reach for convenient reference, in case of need.**
- **In case the system's Units are transferred and reinstalled, the User's Manual should always be attached to the appliance.**

**📖 SAFETY INSTRUCTIONS**

○ Please read carefully the following Safety Instructions before operating the air conditioner.

○ A strict observance of the instructions indicated in this "USER'S MANUAL" will prevent personal hurt and incidents to the User. Moreover, correct operation and long life of the system will be ensured.

○ Depending on the seriousness of potential risks and damages, the reported Instructions are classified in two types: "**WARNING**" and "**CAUTION**". A strict observance of the Instructions is required to guarantee your personal safety and the safety of the environments where the Units are installed.

○ The following Instructions are related to the air conditioner's installation. They have been reported also in the "USER'S MANUAL", just to allow the User to check that installation has been properly carried out. If an improper installation - not corresponding to the Instructions - is verified, please contact the Dealer or the Authorized Technical Service.

**The User must never attempt to repair, install or perform special maintenance of system by himself.**

**📖 KEY OF SYMBOLS**



**WARNING**

○ This symbol points out the risk of serious injury or death.



**CAUTION**

○ This symbol points out the risk of injury or damage to the property.





○ **Prohibition.** Action or procedure not allowed, with serious effects on objects and people.







○ **Obligation.** Compulsory action or procedure. The missed observance could bring serious effects on objects and people.







**🔧 SYSTEM'S INSTALLATION**

○Never try to install this system by yourself, i.e. without the support of Technical Personnel. Never try to repair the system by yourself. The Units' components can be reached only by opening or removing the covering panels, and this involves exposure to high voltage. Even by disconnecting power supply, it is not always possible to avoid the risk of electric shocks.



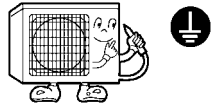













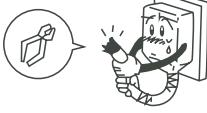

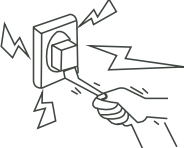

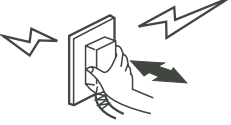

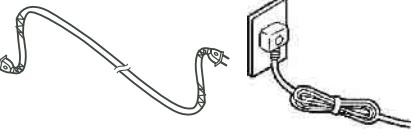

 <b>WARNING</b>	
○ <b>Please always contact the Dealer or the Authorized Service Center for installation.</b> Never attempt to install the air conditioner by yourself, because improper installation could cause electric shock, injuries, water leakage or fire.	
○ <b>Please always contact the Dealer or the Authorized Service Center for any servicing operation or special maintenance.</b> Never try to repair or carry out special maintenance by yourself. Improper repair or maintenance could cause electric shock, injuries, water leakage or fire.	

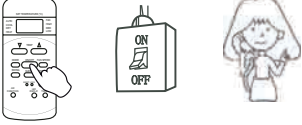













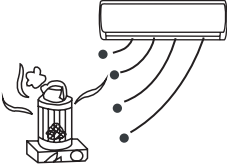

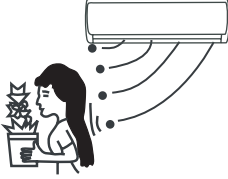





■**Please confirm that installation has been carried out according to the following Prescriptions:**

 <b>WARNING</b>	
○When installing, all possible countermeasures must be taken to avoid refrigerant leaks. If there is a high concentration of refrigerant gas in the room, oxygen lack may occur.	
○Do not install the air conditioner near burners, heat sources or flammable gas. This is to avoid the risk of malfunctioning, fire or explosion.	
○Ensure that a circuit breaker has been installed on the power supply line of the air conditioner, to avoid the risk of electric shocks.	
○When installing in a small room, countermeasures should be taken in case of a refrigerant leak exceeds the proper range (0.3kg/m <sup>3</sup> ). Otherwise, it will cause asphyxia.	

 <b>CAUTION</b>	
○Ensure that drain hose and drain pipe installation has been carried out correctly. Incorrect installation or maintenance will cause water leakage.	
○Ensure that Indoor and Outdoor Units have been properly grounded. Defective grounding could cause electric shock.	 
○This kind of appliance needs a specific circuit breaker with proper protective devices against overcurrent and short circuits (fuses or automatic switches).	 Circuit breaker (specific) 

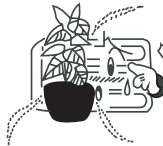
○Always observe the operating precautions listed in the following tables. In this way, correct operation and safeguard of people, animals and objects inside the air-conditioned room will be ensured.

 <b>WARNING</b>	
<p>○Use the correct voltage and frequency for power supply.</p> <p style="text-align: center;"><b>220~240V, 50Hz</b></p>  	<p>○Do not insert the air conditioner's plug into multiple sockets or into sockets to which other appliances are connected. Do not use plug adapters.</p>  
<p>○Fully insert the plug into the power socket and make sure the connection is secure and without play. Otherwise, sparks and fire may occur.</p>  	<p>○Take care not to damage power cable, and do not use faulty cables. Do not put heavy objects on power supply cord.</p>  
<p>○Do not pull the plug out of the power socket by drawing the power cord. Damaging to the power cord, to the plug or to the socket may occur, and this could result in electric shock or fire generation.</p>  	<p>○Never turn off the air conditioner by pulling the power supply plug out of the socket. This could cause electric shock or fire. Always press the "ON/OFF" button on remote control to stop system.</p>  
<p>○Do not apply extension cords to power supply cable. Do not use rolled power supply cords.</p>  	<p>○Never touch system's main switch, plugs, sockets and Emergency Button with wet hands.</p>  
<p>○If you smell something burning, immediately turn off the air conditioner by pressing "ON/OFF" button on remote control, switch the circuit breaker to "OFF" or "0", and contact Authorized Technical Service.</p>  	<p>○Do not insert any object into the air inlet or outlet of Indoor and Outdoor Units. Even if fans are stopped, they could automatically start all at once.</p>  
<p>○You should avoid to expose your body directly to cool air supplied by Indoor Unit for a long time.</p>  	<p>○Do not direct airflow towards children, aged or disabled people.</p>  

 <b>CAUTION</b>	
<p>○Ventilation should be operated when using at the same time the air conditioner and gas burners. Insufficient ventilation may cause lack of oxygen.</p>  	<p>○Do not use sprays near the air conditioner and do not spray anything towards the appliance.</p>  
<p>○Do not place burners near airflow supplied by Indoor Unit.</p>  	<p>○Do not expose plants or animals to direct airflow of air conditioner.</p>  
<p>○For preventing the risk of electric shocks, do not sprinkle water nor other liquid on Indoor Unit. Do not clean the Indoor Unit by water spurts.</p>  	<p>○Ventilate the room regularly while the system is operating. Fail to follow this advice could result in lack of oxygen inside the room.</p>  
<p>○Do not expose food, plants, animals, precise devices or works of art to direct airflow supplied by Indoor Unit.</p>  	<p>○For proper performance, operate the system under the recommended temperature and humidity range. If the Indoor Unit operates beyond these conditions, malfunctions may occur or dew may drip out of Indoor Unit's body.</p>  
<p>○When necessary, replace fuses with new ones of same type. Never replace a fuse by a piece of iron or copper.</p>  	<p>○Do not place anything in front of Indoor Unit.</p>  
<p>○Do not put any object on Indoor Unit. On the appliance's upper part there is an air grille that must not be obstructed. Besides, eventual objects may damage the air conditioner's components. Heavy objects may cause the detachment of Indoor Unit from wall fixation plate.</p>  	<p>○Never touch heat exchangers' metal flaps on Indoor and Outdoor Units. This could cause hurts due to the sharp shape of flaps.</p> 

**(1) Selection of installation site for Indoor Units HKED (261, 351, 531) G**

- Install Indoor Units in a place having the following requirements:
  - The fixing surface must be able to support the Unit's weight.
  - Material features of wall must not cause vibrations.
  - There must be no heating sources nor vapors near the Unit.
  - There must be no obstacles on the air inlet and outlet.
  - Spaces for maintenance and air circulation (inlet and outlet) must be assured.
  - Indoor Unit must not be exposed to direct sunlight for a long time.
  - Drain hose must be correctly installed, so as the condensate water can easily flow away.
  - Laying of cables and refrigerant pipings towards outside must be easy.
  - Air supplied by Indoor Unit must reach whole room.
- Installation must be avoided in places where there are the following conditions (not exhaustive list):
  - There are sources of electromagnetic noises (TV, radio, wireless appliances) or fluorescent lamps.
  - Kitchens with high humidity and vapors/oil sprinkles.
  - There are considerable sudden changes in power supply voltage.

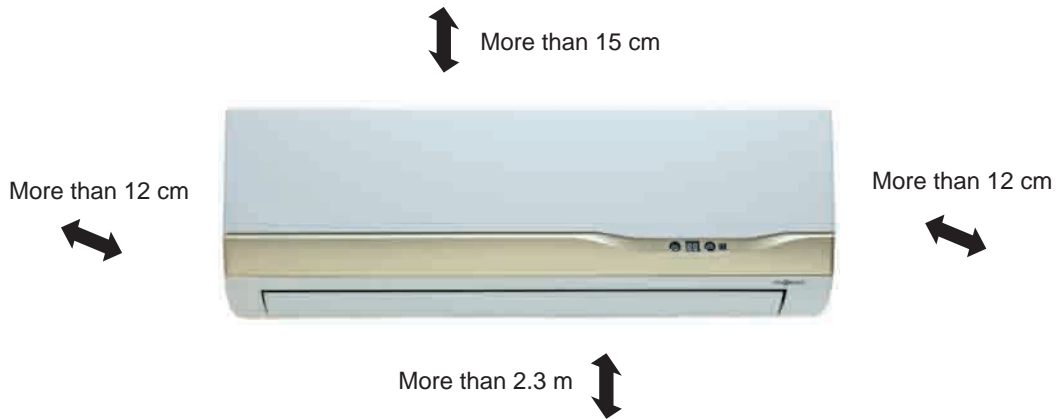

**CAUTION**

Install Indoor Unit to wall, by using the fixation plate, at more than 2.3m high from the floor.

**(2) Piping flaring**

■ If piping's length is too long or its end is damaged, it is necessary to cut it by the special pipe cutter, before carrying out piping flaring.

1. Pipes' cutting

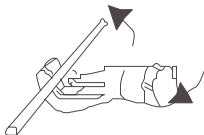

2. Deburring



3. Nuts' insertion

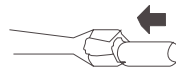



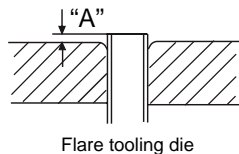
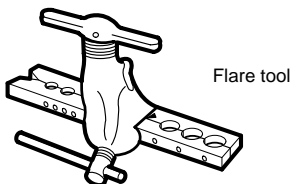

4. Piping flaring

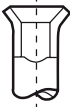
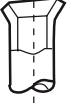
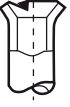

• Dimension "A"

Pipe diameter:	"A" (mm):
6.35 mm (1/4")	0.7~1.3
9.52 mm (3/8")	1.0~1.6
12.7 mm (1/2")	1.0~1.6

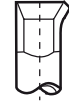
**Examples of piping flaring:**

Correct	Wrong				
 <p><b>OK</b></p>	 <p><b>NO</b> Lean</p>	 <p><b>NO</b> Crack</p>	 <p><b>NO</b> Damage of flare</p>	 <p><b>NO</b> Partial</p>	 <p><b>NO</b> Too outside</p>

**(3) Fixing of installation plate**

The surface to which fixing plate will be installed must be perfectly vertical.

The surface to which fixing plate will be installed must be as regular as possible.

The fixing surface must be able to carry the weight of Indoor Unit easily. Otherwise, Indoor Unit may detach from wall and fall down, causing injuries to people and damages to objects.

Fixing surface must not amplify vibrations generated by Indoor Unit during operation.

Fixing surface must not amplify noise level generated by Indoor Unit, so as not to cause acoustic resonance phenomenons.

Fixing surface of plate must be in good condition, that is it must not have cracks nor marks of plaster's detachment.

Do not install fixing plate on walls from which humidity oozes.

Do not install fixing plate on metal vertical panels.

Do not install fixing plate on wooden vertical panels or on flammable material panels.

Do not suspend Indoor Unit to a fixing plate that is installed on plasterboard wall.

Select installation position of fixing plate, so as all around Indoor Unit - that is on four sides - appropriate installation and service spaces are available for installation and maintenance operations of Indoor Unit.

Once installation position of fixing plate has been selected, fix the plate temporarily by a wall nail and level it horizontally by a spirit level.

Previously mark by a pencil on fixing surface the points where screw anchors must be positioned for definitive fixing of plate, in order to avoid to make holes in wrong places.

For definitive fixing of plate, **use 6/8 screw anchors 5mm.**

Select screw anchor suitable for material features of fixing surface.

**(4) Drilling of wall**

- Drill a hole of about 65mm diameter on wall, by using a wall cutter (Ø65mm).
- Drill the hole with a light incline from indoor side to outdoor side, as it is shown on Figure on the right.
- Insert the sleeve for wall hole and seal it with putty.

■ Installation of sleeve for wall hole:

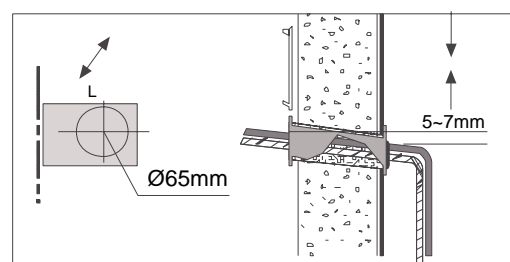

■ Indoor Unit HKED 261 G: Measures of fixing plate for wall installation

Unit: cm

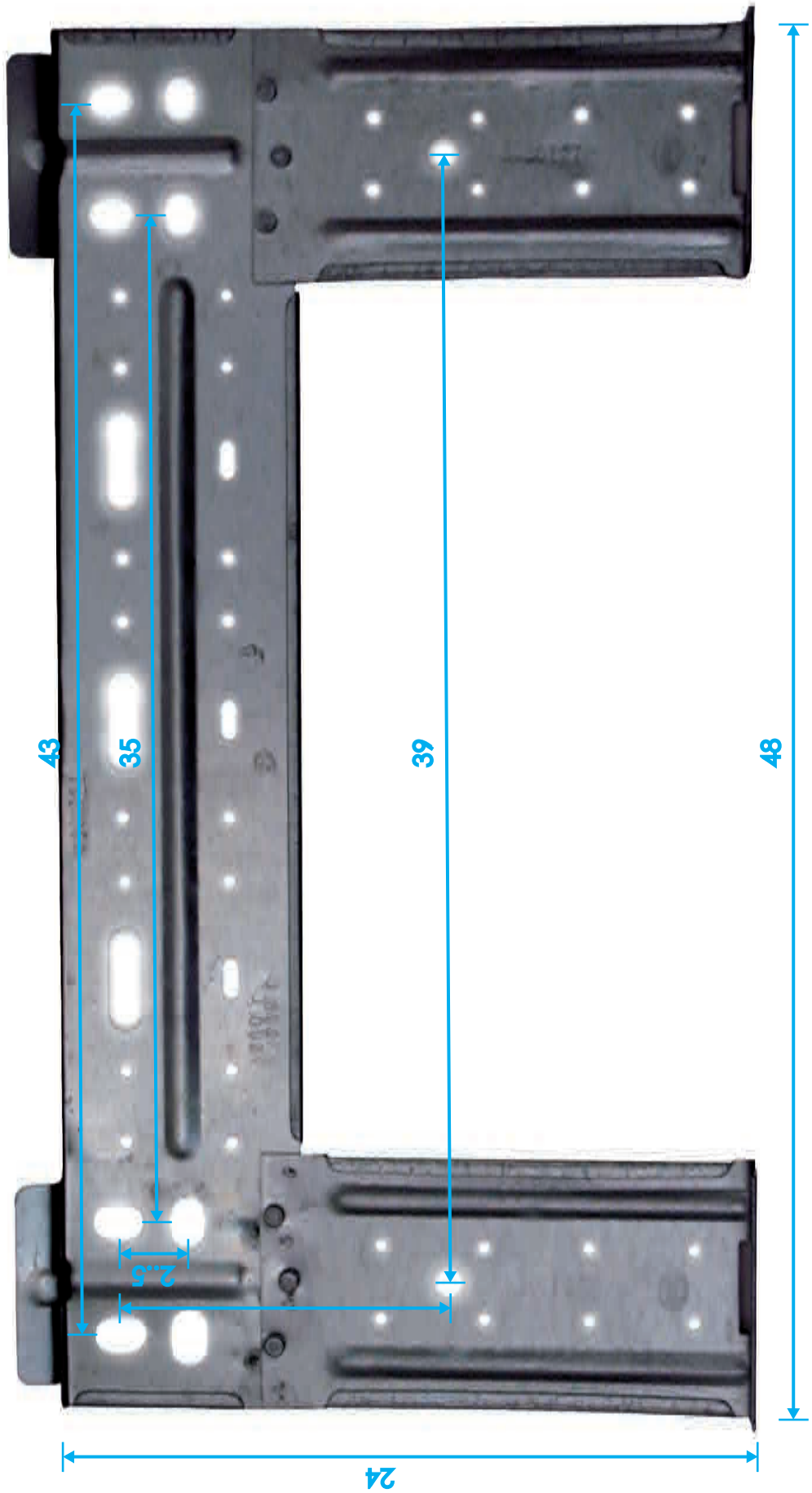

■ Indoor Unit HKED 351 G: Measures of fixing plate for wall installation

Unit: cm

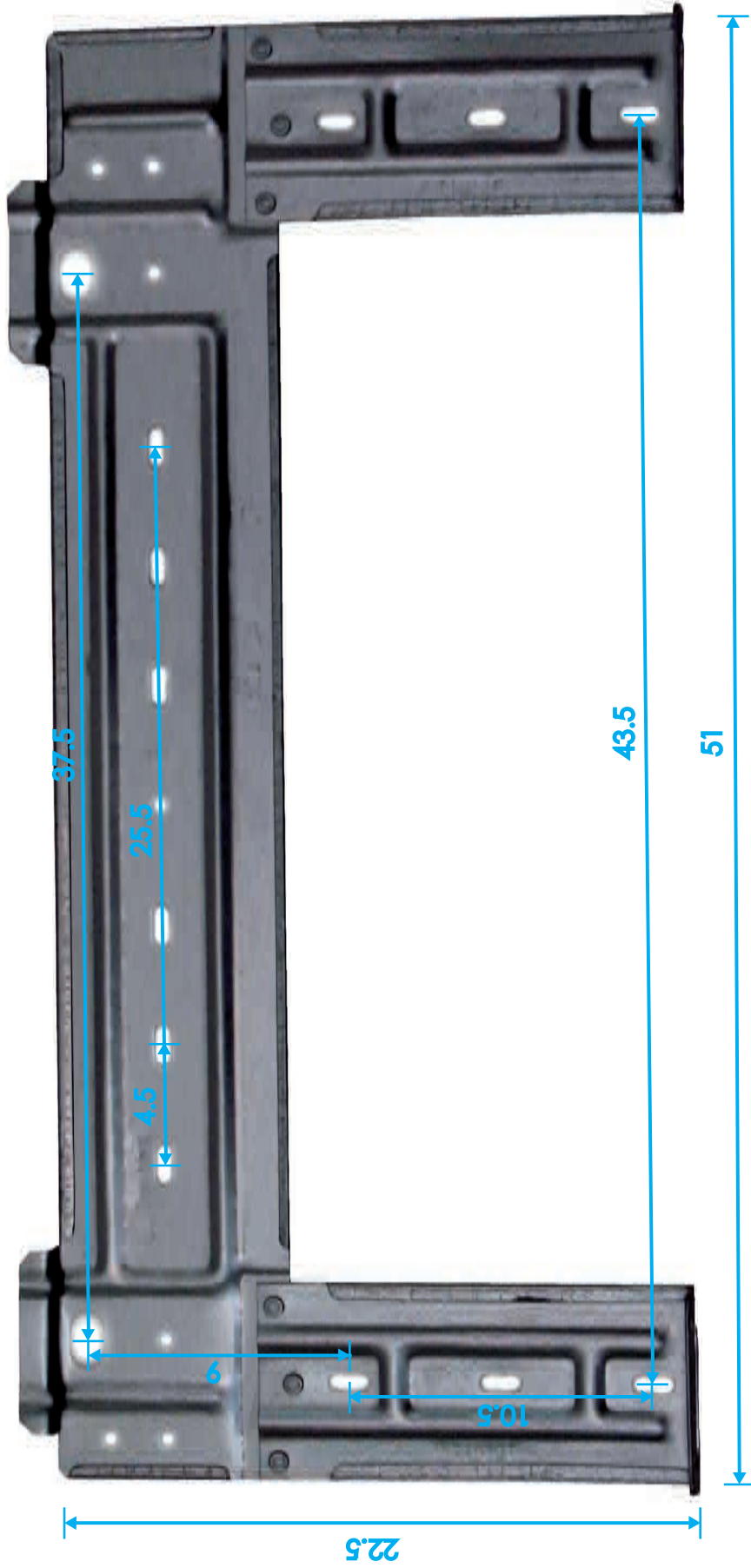

■ Indoor Unit HKED 531 G: Measures of fixing plate for wall installation

Unit: cm

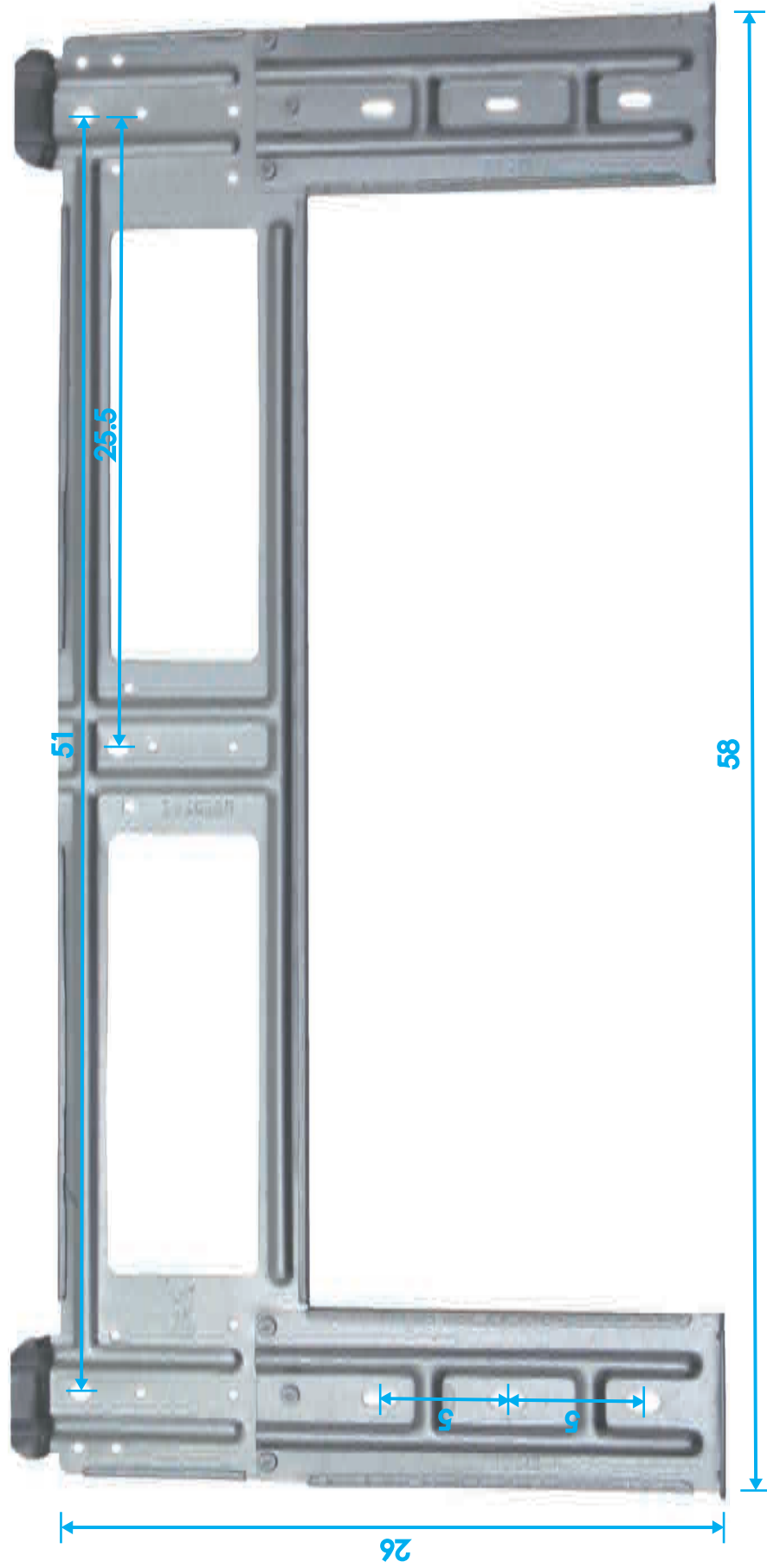

**(5) Disposal of pipings and cables**

a) Right-rear and left-rear outlet of pipings:

○Take out refrigerant pipings and flexible drain hose from Indoor Unit and orient them properly according to installation needs.

b) Left-side outlet of pipings:

○In case of pipings' outlet on left side, remove the corresponding precut part. After removing precut part, take care to remove completely eventual protrusions of plastic material on hole's edges, as they are sharp and may damage especially power supply cable and wiring.

○Properly orient Indoor Unit's refrigerant pipe fittings and flexible drain hose.

c) Right-side outlet of pipings:

○In case of piping outlet on right side, remove the corresponding precut part. After removing precut part, take care to remove completely eventual protrusions of plastic material on hole's edges, as they are sharp and may damage especially power supply cable and wiring.

○Properly orient Indoor Unit's refrigerant pipe fittings and flexible drain hose.

■ Right-side direction

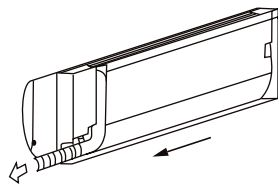

■ Left-side direction

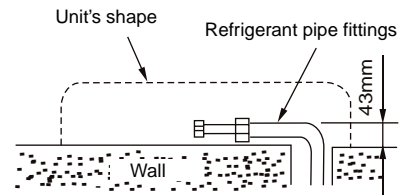
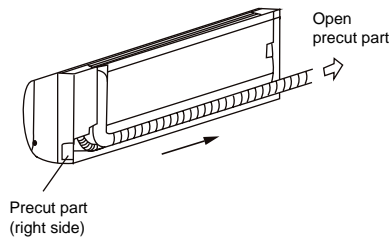

Note: In case of right-side or left-side outlet of refrigerant pipings, bend refrigerant pipe fittings so as to keep a distance not higher than 43mm between refrigerant pipe fittings and wall, as it is shown in the Figure.

■ Rear-right direction

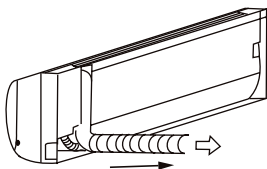

■ Rear-left direction

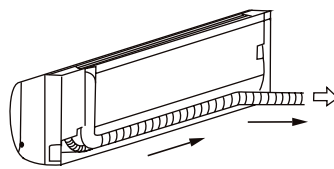

**(6) Access to terminal block for wiring**

a) Open frontal panel

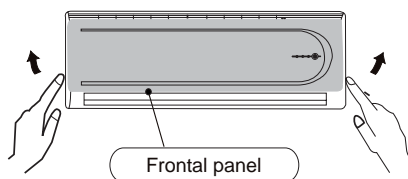

○Press both sides of panel and lift it till reaching max. opening angle (about 60°).  
○Never force panel more than max. opening angle.

b) Remove cover of terminal block

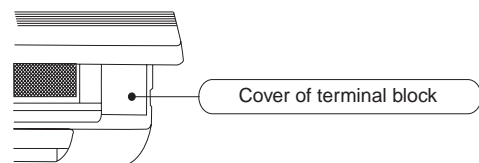

○Below the frontal panel there is electric box's cover, which is fixed by a screw.  
○Remove the cover's fixing screw and then cover itself, so as to reach power supply terminal block for connection between Indoor and Outdoor Units.

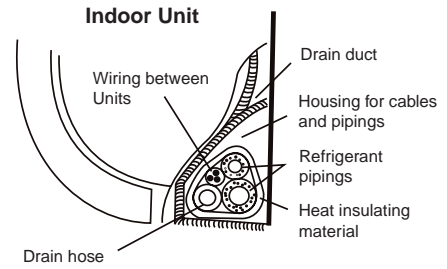
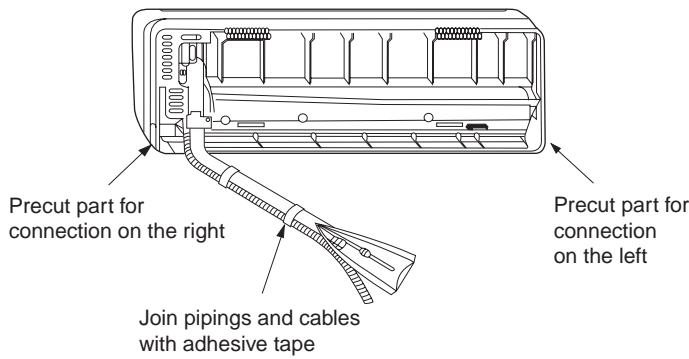

**Keep in mind the following:**

1. Wiring between Indoor and Outdoor Units and drain hose, must be taped together with refrigerant pipings, by using adhesive tape.
2. The corresponding position of pipes and cables is indicated on the above Figure on the right, that is drain hose must be kept downwards, electric cables higher and refrigerant pipings on rear side.
3. In case of left-side outlet (case described at item "b") or rear-left outlet of pipings, fix the whole of pipings and cables to Indoor Unit by special clips.
4. This air conditioning system requires insulation of pipings and of related connection points both on gas side and liquid side, as they can both reach low temperatures or high temperatures (depending on mode) during operation.

○Strictly tape (no air pocket must be left between connections and insulating material) connection points by using heat insulating material, and seal by adhesive tape. If you fail this precaution, condensate may form on connection points, and water may drip inside the room.

**(7) Fixing of Indoor Unit**

Temporarily suspension of Indoor Unit on upper hooks of fixing plate:

○Insert a spacer (wooden block or other object) between Indoor Unit and fixing plate, so as to separate the Unit's base from the wall and get space for carrying on work.

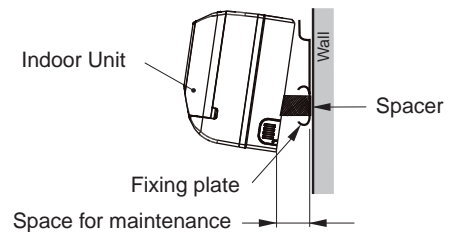

**(8) Refrigerant pipings**

○Oil flares' back and indoor side of flare nuts by refrigerant synthetic oil.

○Align to pipe fittings the axis of pipings to be connected and screw flare nuts on threaded pipe union of Indoor Unit.

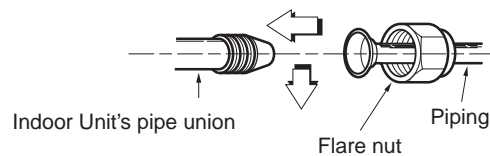

○At first tighten the connection manually as much as possible.

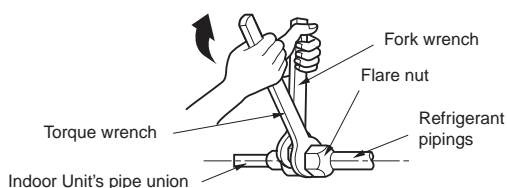

Fastening torque and pipe diameter	
LIQUID Side	GAS Side
17.6 N•m (1/4")	41.2 N•m (3/8")
	53.9 N•m (1/2")

○Tighten the connection definitively with a torque wrench and a spanner:

**(9) Position of drain hose**

○As regards the whole formed by wiring and refrigerant pipings, drain hose must be positioned downwards, as it has already previously said. Besides, in particular, the first portion of drain hose - that is the portion which is inside Unit - must be covered by insulating material.

○In the Figure below, **some examples of incorrect installation** of drain hose are shown. It is a matter of most common errors during installation phase (so they must be avoided).

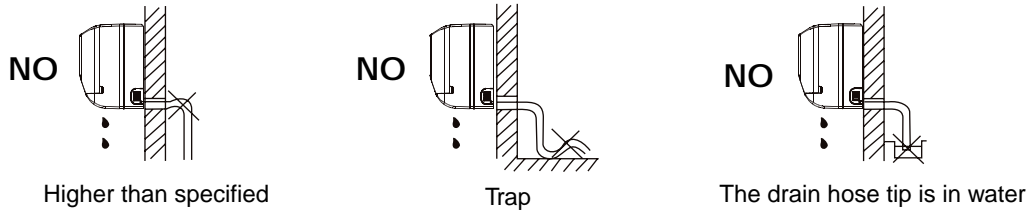

○The connection of drain hose is on right side of Indoor Unit only. If it is necessary to extend drain hose, use a pipe in semirigid plastic material (PVC) of VP16 type, to buy separately.

○Connect the extension by using a special fitting.

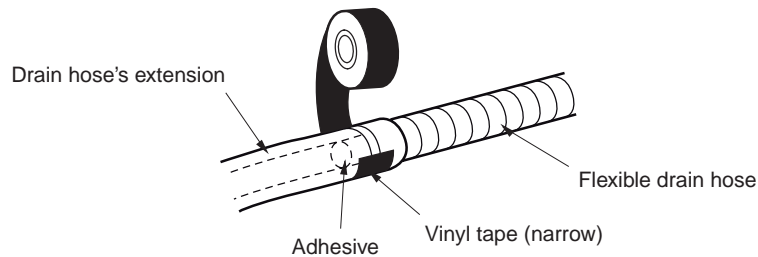

**(10) Wiring**

1. Wiring between Indoor Unit and Outdoor Unit (4 cables + Ground wire: min. section of 1.5mm<sup>2</sup> for Models 261 G and 351 G; min. section of 2.5mm<sup>2</sup> for Model 531 G) must start from Indoor Unit's back and get to connection terminal block of Outdoor Unit. Use cables in accordance with to law only.
2. Terminal block can be reached by removing electric box's protection cover - which is fixed by a screw - placed on Indoor Unit's right side, below up-and-over panel.
3. Firmly fix cables on screw terminal blocks, and always use the special pipe clips to avoid that any traction on the cable may be sent to terminal blocks' contacts.
4. If protection fuse on Indoor Unit is broken, replace it by a fuse which is equivalent to original one.
5. Power supply line must be for system only, that is it must not be shared with other appliances. A switch must be installed which interrupts all contacts (in opening position, min. distance between contacts must be of 3 mm). Moreover, the installation of a circuit breaker is required, with suitable calibration (10A for Model 261 G; 16A for Models 351 G and 531 G).

**Passage of wiring, connection of terminals and use of wire clips**

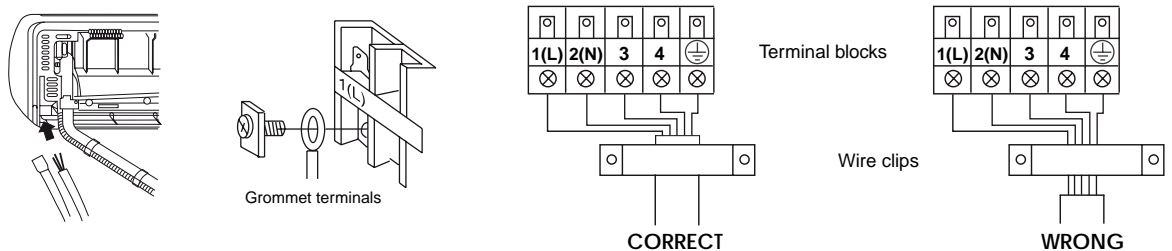

**Example of wiring: "Constant Speed" Models HKED-HCND 261, 351, 531G**

**☞ Power supply (on Indoor Unit):**

1-Phase, 220~240V, 50 Hz.

**☞ Calibration of circuit breaker and power supply switch:**

- Model 261 G 10A
- Models 351 G and 531 G 16A.

**☞ Min. section of power supply cables:**

- Models 261 G and 351 G 1.5mm<sup>2</sup>
- Model 531 G 2.5mm<sup>2</sup>.

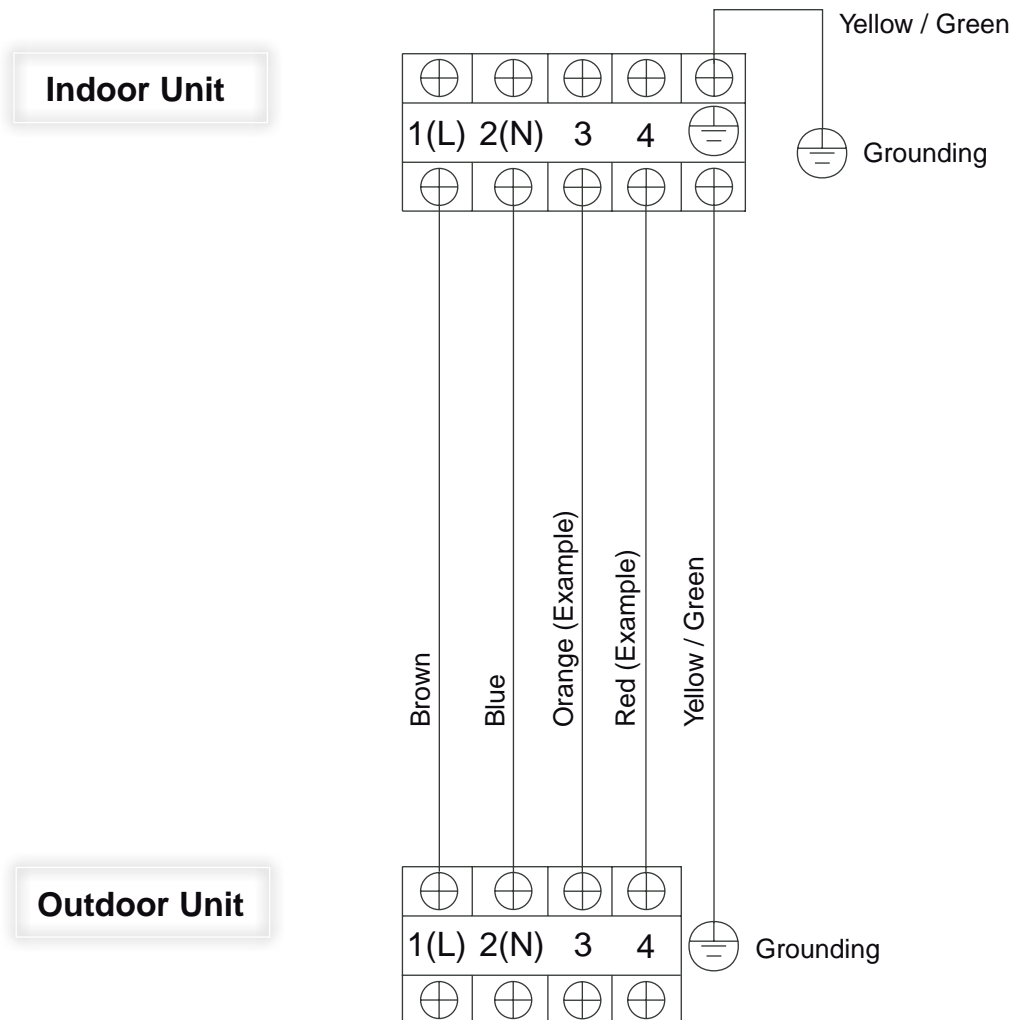

**☞ Min. section of wiring between Units:**

- Model 261 G 1.5mm<sup>2</sup>
- Models 351 G and 531 G 2.5mm<sup>2</sup>.

**(11) Definitive fixing of Indoor Unit**

1. Remove the spacer.
2. Suspend Indoor Unit to upper hooks of fixing plate and move Unit left side and right side to check if it is properly fixed.
3. In the end, hold Unit on both sides firmly, and press it on the installation plate till definitive fixing.

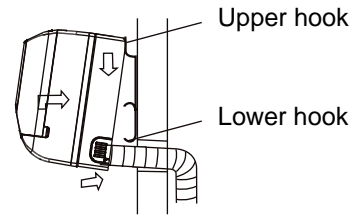
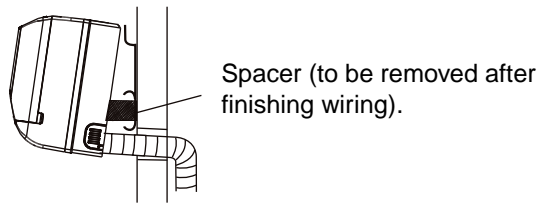

**(12) Final checks**

1. Check way and laying of drain hose and electrical wiring.
2. Check the correspondence between wires and terminals on terminal blocks of wiring between Indoor Unit and Outdoor Unit.
3. Check heat insulation of refrigerant pipings and drain hose.
4. Check correspondance of power supply as regards plate specifications required by system.
5. Check correct water drainage through drain hose.
6. Check if Indoor Unit is fixed to wall fixing plate firmly.
7. Check if there are refrigerant leakages near refrigerant connections (Flare connections).

**(13) Test of system**

- Start system normally by using IR remote control.
- The system's test in Cooling mode is possible at room temperature not lower than 17°C.
- The system's test in Heating mode is possible at room temperature not higher than 31°C.



**■During the test, first check the following:**

1. Is it possible to adjust room temperature as you like?
2. Is it possible to change fan speed according to comfort needs?
3. Are there abnormal noises and/or excessive vibrations coming from Indoor and/or Outdoor Units?
4. Do horizontal outlet flap and vertical louvers properly reply to impulses sent by remote control, and do they work properly in "SWING" and "AIR FLOW" modes?
5. Does air supplied by Indoor Unit reach all installation environment uniformly?
6. Does condensate water drip from Indoor Unit into the room?
7. Does temperature difference between inlet and outlet ( $\Delta T$ ) on Indoor Unit show a satisfactory performance of system?

### 5.3 INSTALLATION OF OUTDOOR UNITS HCND 261, 351, 531 G

**■ Accessories required**

The following accessories must be available for Outdoor Unit's installation:

Nb.	Appearance	Description	Quantity
1		Drain elbow	1
2		Rubber pads	4
3		Clip	1

**■ Selection of place and installation position**

- Place and supporting surface must not amplify vibrations generated by Outdoor Unit.
- The supporting surface must be able to bear Outdoor Unit's weight.
- Air outlet must be oriented to 90° as regards wind's prevailing direction.
- Noise generated by Outdoor Unit must not disturb the neighbours.
- A place where condensate or defrosting water drainage do not disturb to people nor damages to objects.
- Installation of a concrete bed for Outdoor Unit must be possible.
- The projection of anchor bolts (4 x Ø8mm, or 4 x Ø10mm) for Outdoor Unit's base, must be of about 20mm as regards concrete bed.
- Please keep Outdoor Unit in safety by reinforcing the fixing system, if Outdoor Unit is exposed to strong wind or it may fall because of earthquakes or exceptional climatic occurrences.
- The installation of a snow shelter must be possible, according to climatic recurrent conditions in the environment.
- Sufficient spaces must be kept free for repairing and maintenance of Unit.
- Splitting level differences and max. splitting distances that are foreseen for system must be observed, also by taking into consideration the position of Indoor Units which belong to the system.
- A power supply line has to be prepared having such features as to respect the specifications required by system. The wires of this power line must have a section suitable to the system's features. Besides, the power line must be provided of a power switch and circuit breaker having a calibration suitable to the system's absorption features, that are indicated on Outdoor Unit's plate.

**■ Models HCND 261, 351, 531 G: Dimensions for installation**

Unit: mm

Dimension Model	Width	Height (Max.)	Depth	Distance between centers > holes	Distance between centers > holes
	HCND 261 G	700	500	225	510
HCND 351 G	795	540	255	510	278
HCND 531 G	795	540	255	510	278

**Overall view of installation**

1. When chased laying is carried out of refrigerant pipings, take care to seal the ends of these refrigerant lines, by pinching and welding them so as to protect them from infiltrations.
2. Check if chosen pipings have such diameters and features (copper thickness) as to be suitable to Units which belong to system and to R410A refrigerant.

**Fixing plates**

○Mod. HKED 261 G



○Mod. HKED 351 G



○Mod. HKED 531 G



**IR Remote Control**



**Indoor Unit**

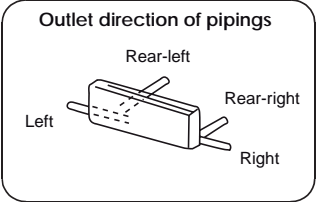

Cover the pipings with closed cells' insulation material, resistant to temperatures of at least 120°C. It is important that there is no air pocket between insulating material and material which wraps refrigerant pipings.

Finishing of installation: strictly tape insulating material that wraps refrigerant pipings, by proceeding from the bottom upwards.



**Outdoor Unit (Example: HCND 351 G)**



NOTE: at least 2 of sides that are indicated in the Figure by "A", "B" and "C" must be kept free from obstacles.

**Notes:**

1. If there is the risk Outdoor Unit may fall down or overturn, it is advised to install tie rods in addition to anchor bolts (4 x Ø8mm, or 4 x Ø10mm) on Indoor Unit's base.
2. The installation of a raised bearing bed as regards ground prevents snow from piling up around Outdoor Unit, and at the same time it makes easier condensate and defrosting water drainage.
3. Take care to fix Outdoor Unit by keeping it leveled as regards horizontal surface.

■ **HKED-HCND 261 G: Limits related to distances and splitting level distances**

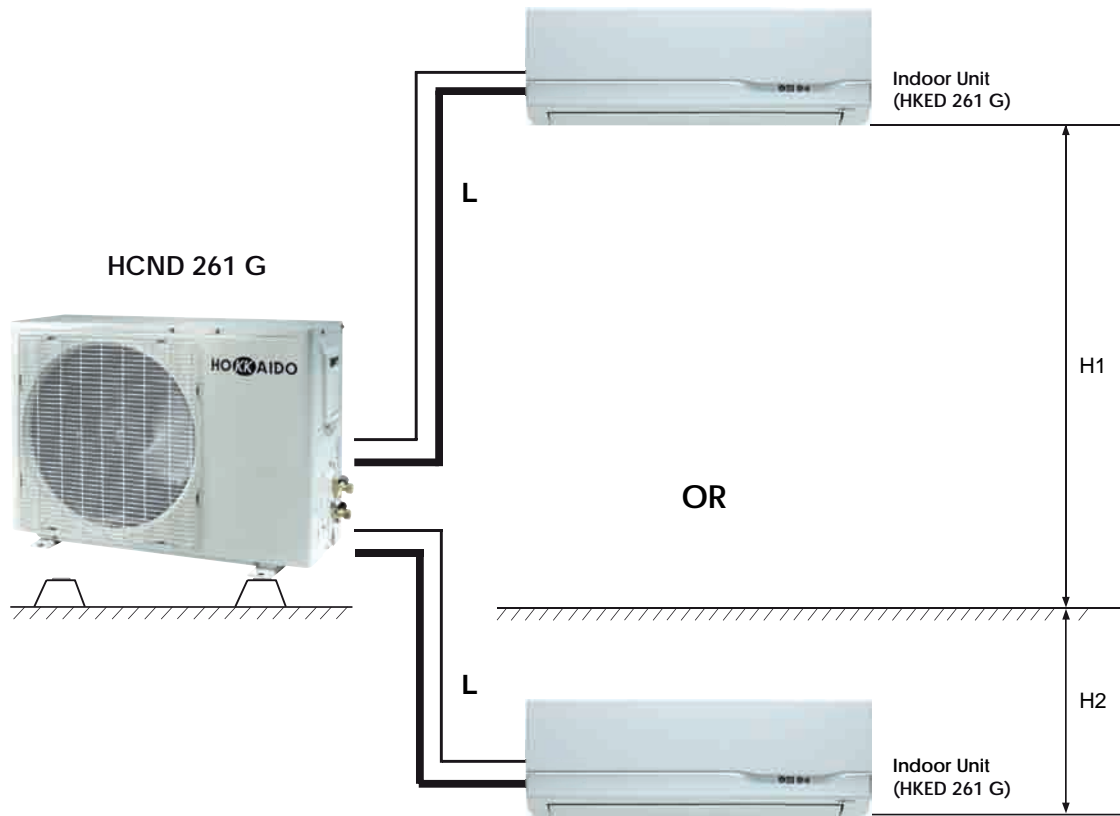

○ **Distances and splitting level distances**

Item	Unit	Description	Measure
Liquid Side	mm	Piping's diameter	Ø6.35 (1/4")
Gas Side	mm	Piping's diameter	Ø9.52 (3/8")
L (one line)	m	Splitting distance	Max. 15m
L <sub>Standard</sub>	m	Piping's standard distance (on liquid side) for which no additional charge is required (*)	3.5m
H2	m	Splitting level distance between O.U. (higher) and I.U.	Max. 5m
H1	m	Splitting level distance between O.U. (lower) and I.U.	Max. 5m

(\*) NOTE: If splitting distance is more than 3.5m (liquid side), additional charge is: 30g/m of R410A.

■ **Refrigerant pipings**

1. Selection of pipings and specifications

○Thermally insulate pipings on liquid side and gas side, as according to operation mode, both of them may reach low temperatures during the system's operation.

○Use close cells' insulating material, in addition to the material that already wraps the pipings, which is resistant to temperatures of at least 120°C.

<b>Piping, Liquid Side</b>	Ø6.35mm (1/4") x 0.8mm
<b>Piping, Gas Side</b>	Ø9.52mm (3/8") x 0.8mm

■ **HKED-HCND 351 G: Limits related to distances and splitting level distances**

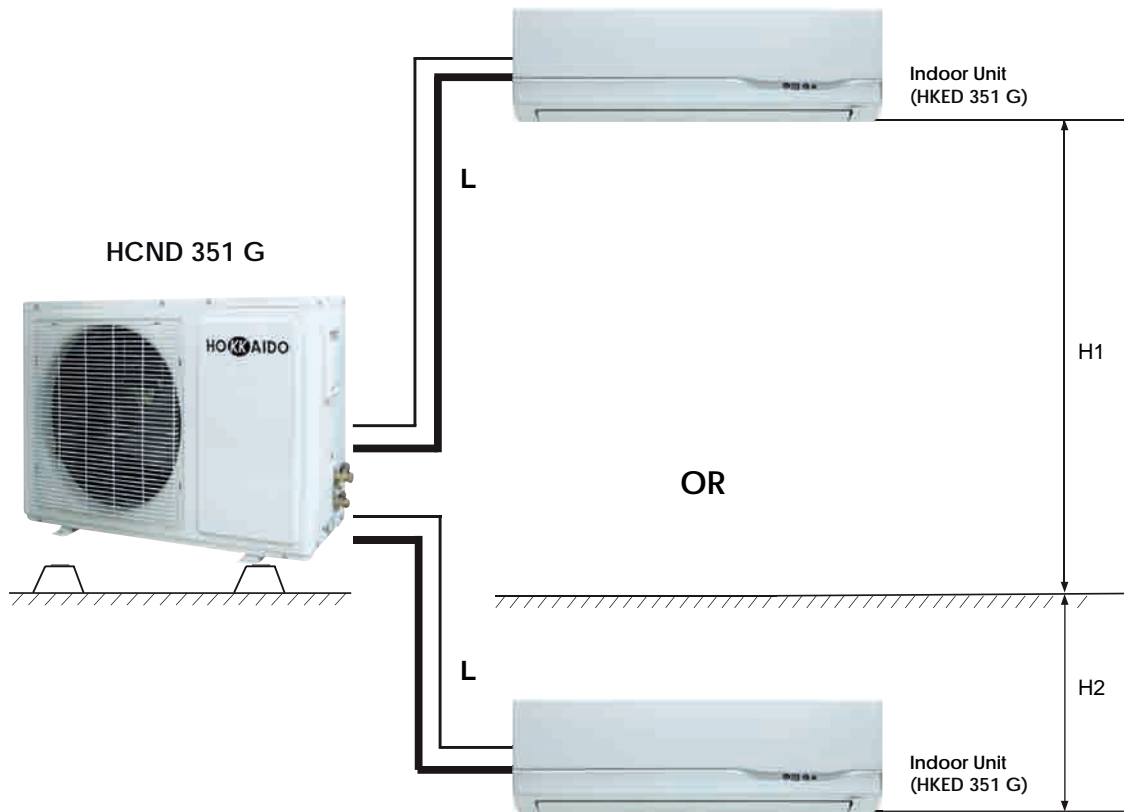

○ **Distances and splitting level distances**

Item	Unit	Description	Measure
Liquid Side	mm	Piping's diameter	Ø6.35 (1/4")
Gas Side	mm	Piping's diameter	Ø9.52 (3/8")
L (one line)	m	Splitting distance	Max. 15m
L <sub>Standard</sub>	m	Piping's standard distance (on liquid side) for which no additional charge is required (*)	3.5m
H2	m	Splitting level distance between O.U. (higher) and I.U.	Max. 5m
H1	m	Splitting level distance between O.U. (lower) and I.U.	Max. 5m

(\*) NOTE: If splitting distance is more than 3.5m (liquid side), additional charge is: 30g/m of R410A.

■ **Refrigerant pipings**

1. Selection of pipings and specifications

○Thermally insulate pipings on liquid side and gas side, as according to operation mode, both of them may reach low temperatures during the system's operation.

○Use close cells' insulating material, in addition to the material that already wraps the pipings, which is resistant to temperatures of at least 120°C.

<b>Piping, Liquid Side</b>	Ø6.35mm (1/4") x 0.8mm
<b>Piping, Gas Side</b>	Ø9.52mm (3/8") x 0.8mm

■ **HKED-HCND 531 G: Limits related to distances and splitting level distances**

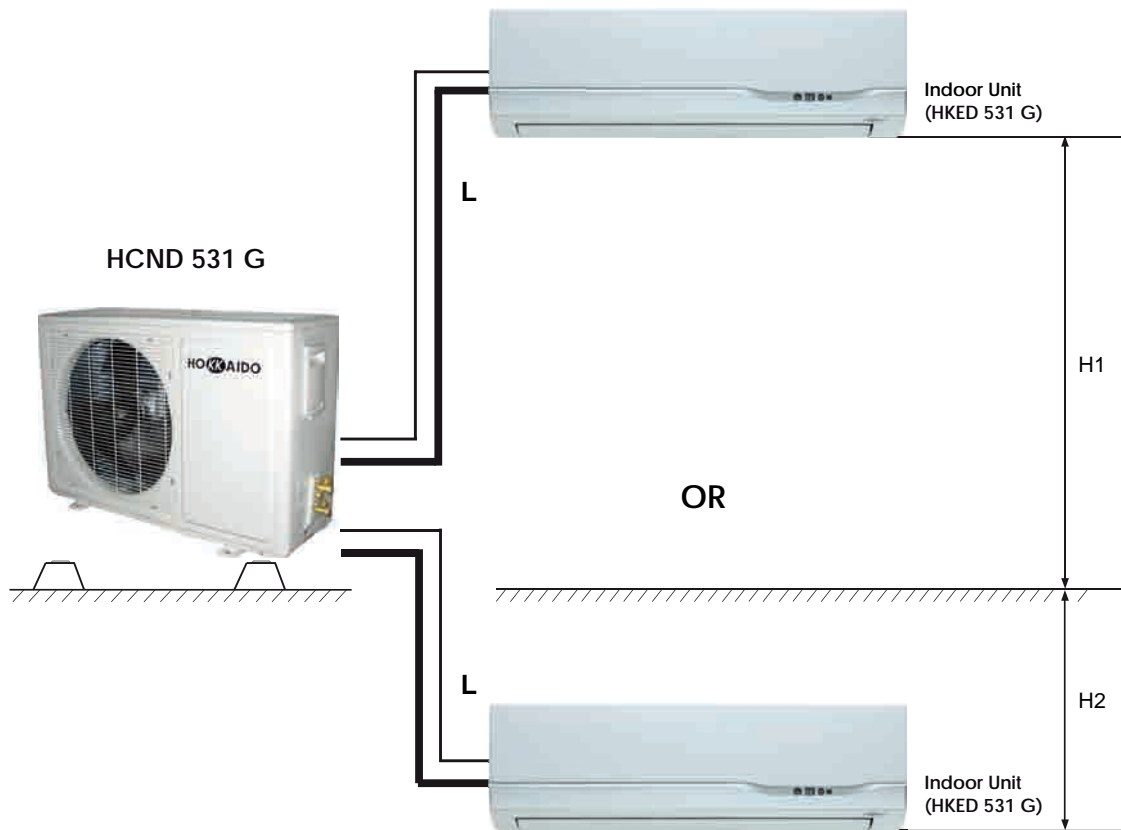

○ **Distances and splitting level distances**

Item	Unit	Description	Measure
Liquid Side	mm	Piping's diameter	Ø6.35 (1/4")
Gas Side	mm	Piping's diameter	Ø12.7 (1/2")
L (one line)	m	Splitting distance	Max. 15m
L <sub>Standard</sub>	m	Piping's standard distance (on liquid side) for which no additional charge is required (*)	4.0m
H2	m	Splitting level distance between O.U. (higher) and I.U.	Max. 5m
H1	m	Splitting level distance between O.U. (lower) and I.U.	Max. 5m

(\*) NOTE: If splitting distance is more than 4.0m (liquid side), additional charge is: 30g/m of R410A.

■ **Refrigerant pipings**

1. Selection of pipings and specifications

○Thermally insulate pipings on liquid side and gas side, as according to operation mode, both of them may reach low temperatures during the system's operation.

○Use close cells' insulating material, in addition to the material that already wraps the pipings, which is resistant to temperatures of at least 120°C.

<b>Piping, Liquid Side</b>	Ø6.35mm (1/4") x 0.8mm
<b>Piping, Gas Side</b>	Ø12.7mm (1/2") x 0.8mm

**2. Pippings' cutting and flaring**

- Cut pippings according to the desired length, by using the special roller pipe cutter.
- After finishing operation, remove the burr from pippings' ends by using the deburring tool.
- Insert flare nut on piping before carrying out the flaring.

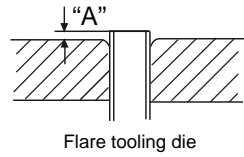
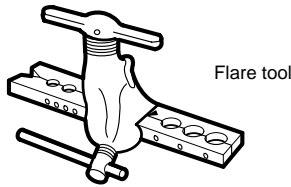

**○Dimension "A"**

Pipe diameter:	"A" (mm):
6.35 mm (1/4")	0.7~1.3
9.52 mm (3/8")	1.0~1.6
12.7 mm (1/2")	1.0~1.6

**Example of flaring:**

Correct	Wrong				
 <b>OK</b>	 <b>NO</b> Lean	 <b>NO</b> Damage of flare	 <b>NO</b> Crack	 <b>NO</b> Partial	 <b>NO</b> Too outside

**3. Esecuzione dei collegamenti frigoriferi**

- Remember to apply refrigerant synthetic oil on flares' back and on flare nut's inside before fastening the flare nuts, so as to assure the connections' tightness.
- Always use a tube bender for bending the pippings, and take care that radius of curvature is always wide enough, so as to avoid narrowings on pippings.
- Carry out connection on gas side first, and then on liquid side, as piping on gas side has a larger diameter and requires wider operation distances.

**CAUTION:** Always centre the piping on Outdoor Units' refrigerant fitting before screwing by hand the flare nut and carrying out definitive tightening. Neglecting this device will cause damages to flare nuts' threads and to refrigerant fittings. Moreover, flares will be deformed with consequent refrigerant leakages. Use a spanner for holding still the Outdoor Unit's refrigerant fitting and avoiding its torsion. Use a torque wrench for tightening flare nuts. Respect recommended fastening torques.

Piping diameter (Ø)	Fastening torque
Liquid side: 6.35mm (1/4")	17.6 N•m
Gas side: 9.52mm (3/8")	41.2 N•m
Gas side: 12.7mm (1/2")	53.9 N•m

**4. Installation of drain elbow on Outdoor Unit**

- This accessory, provided with the Unit, allows connection of a drain piping for condensate or defrosting water.
- Avoid to install the drain elbow in places where outdoor temperatures are very low (about or lower than 0°C) for long time periods.

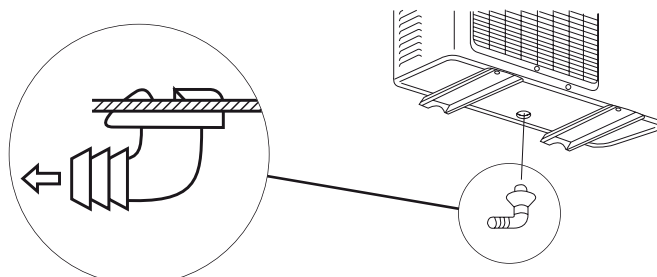

■ **Electric wiring**

The electrical work must be carried out by Authorized Technical Personnel, that observes national and local current regulations.

1. Power supply line (on Indoor Unit) must be for air conditioner only. Install a switch that interrupts all contacts ( in opening position, min. distance between contacts must be of 3 mm). It is required the installation of a circuit breaker with a suitable calibration (10A for Model 261; 16A for Models 351 and 531).
2. Ground wire and neutral wire on power supply line must be kept separately.
3. Use only copper wires and in accordance with to law.
4. Respect the correspondance between the colour of wires' sheathings and terminal blocks' contacts, both on Indoor and Outdoor Units.
5. Power supply specifications are the following: 1-Phase, 220~240V, 50 Hz.
6. If protection fuse on Indoor Unit is damaged, it must be replaced by another fuse of original or equivalent type. Nevertheless, first of all it is needed to look for the reasons of fuse's damaging.
7. The min. recommended sections for cables are the following:
  - a) Models 261 G and 351 G: 1.5mm<sup>2</sup>.
  - a) Model 531 G: 2.5mm<sup>2</sup>.
8. To reach Outdoor Unit's terminal block, remove protection cover (fixed by screws) placed on Outdoor Unit's right side. The electric wiring must make a bend (a sort of "U") before entering Outdoor Unit's electric box. This device is for preventing infiltrations of rain.
9. Firmly fix each wire to the corresponding contact on screw terminal blocks, and always use the special wire clips to avoid eventual tractions applied to cables to be transmitted to terminal blocks' contacts.

**Access to terminal blocks, terminals' connections and use of wire clips**

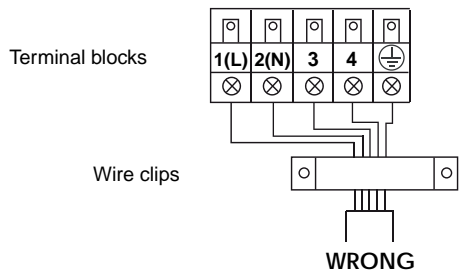
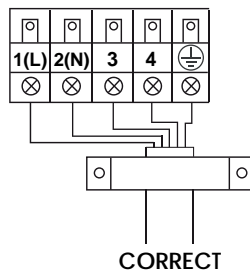
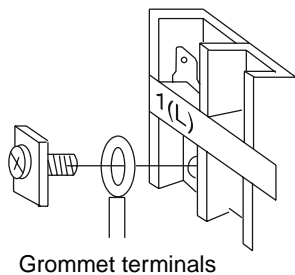

## ■ Final checks

Before supplying power to the system:

1. Check the correspondance between wires and terminals on terminal blocks for connection between Indoor Unit and Outdoor Unit.
2. Check heat insulation of refrigerant pipings.
3. Check if condensate and defrosting water drainage takes place properly. Check if a drain pipe has been installed on Outdoor Unit's base.
4. Check the correspondance of power supply as regards plate specifications required by system, indicated on identifying plates of each Model.
5. Check if Outdoor Unit is fixed firmly to the supporting surface (possibly in masonry and in excellent condition) and well leveled horizontally.
6. Make sure that vacuum of refrigerant pipings and of Indoor Units' refrigerant circuit has been carried out. Also make sure that additional charge, if required, has been carried out too.
7. Check if service valves on Outdoor Unit are completely open, both on gas and liquid sides.
8. Check if there are no leakages of refrigerant gas near refrigerant connections, by using a high-sensitivity gas leak detector for HFC.

## ■ Test of system

- Start normally the system by using IR remote control.
- Test of system in Cooling mode is possible if room temperature is not lower than 17°C.
- Test of system in Heating mode is possible if room temperature is not higher than 31°C.

### ■ During the Test, first of all check the following:

1. Is it possible to adjust room temperature according to your needs?
2. Is it possible to change fan speed as it is required by your comfort needs?
3. Are there abnormal noises and/or excessive vibrations deriving from Indoor Unit and/or Outdoor Unit?
4. Do outlet horizontal flap and vertical louvers reply properly to impulses sent by remote control, and do they move properly in "SWING" and "AIR FLOW" modes?
5. Does air supplied by Indoor Unit reach the installation environment uniformly?
6. Does condensate water drip from Indoor Unit into the room?
7. Does temperature difference between inlet and outlet ( $\Delta T$ ) on Indoor Unit show a satisfactory performance of system?

## 5.4 VACUUM PROCEDURE AND REFRIGERANT CHARGE

### (1) Why vacuum operation is needed

○ Vacuum procedure is necessary to remove the impurities, the remains of not condensable gas, the air and humidity from refrigerant circuit, by a vacuum pump (equipped of one-way valve to avoid oil infiltrations, deriving from the pump, inside refrigerant circuit, in case of accidental stop of pump during vacuum operation).

○ As R410A refrigerant is highly insoluble in water, even a small amount of remaining humidity inside refrigerant circuit may freeze and cause the clogging of the circuit itself.

### (2) Vacuum procedure of refrigerant pipings

**a)** Make sure there is no pressure inside Indoor Units and inside refrigerant pipings. This may be detected by check joint (needle valve) placed on service valve (gas side) of Outdoor Unit.

**b)** Connect service pipings from the pump to gaugemanifold and from gaugemanifold to check joint (needle valve) placed on service valve (gas side) of Outdoor Unit.

Gaugemanifold and service pipings must be of specific type for R410 A refrigerant.

**c)** Carry out operations according to the following sequence.

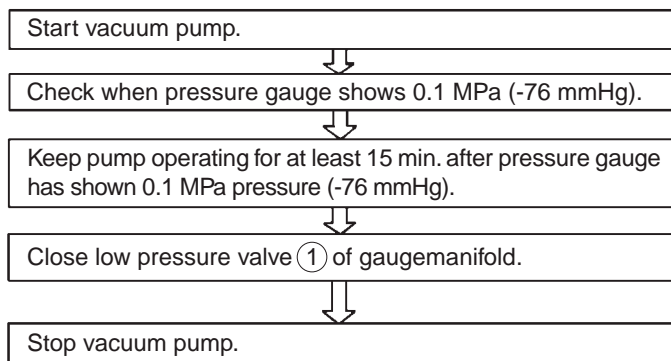

**Notes:**

- (1) Do not use refrigerant pressure for expelling air from the circuit. The so-called "purging" method is not allowed in conformity with current regulations.
- (2) Never operate compressor for carrying out vacuum operation.
- (3) Do not start compressor during vacuum condition.

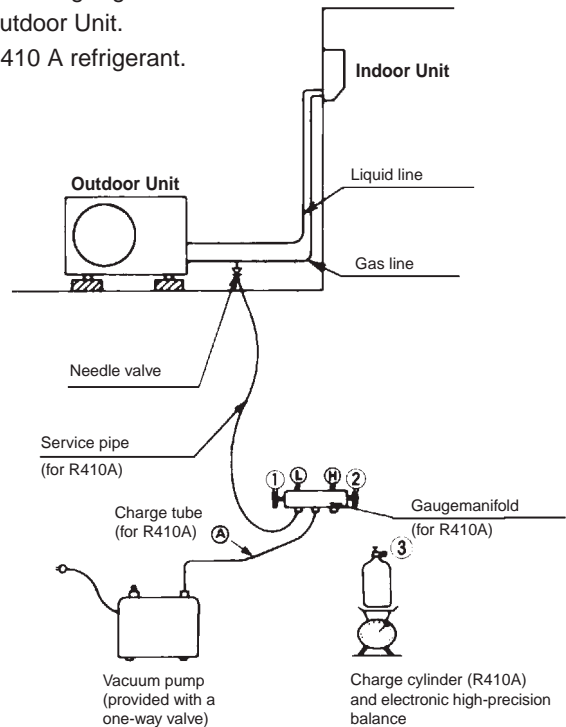

### (3) Recharge of refrigerant

**a)** Discharge completely refrigerant from the circuit (by recovering it) and carry out the vacuum as it has already been described.

Do not charge refrigerant before carrying out the vacuum, as this modifies operating conditions of system and leads to excessive or insufficient charge of refrigerant.

**b)** Keep gaugemanifold connected and connect charge cylinder which contains the refrigerant.

**c)** Place charge cylinder on precision electronic balance, and write down its weight. This is for measuring the exact amount of refrigerant that will be introduced in the refrigerant circuit.

**d)** Eliminate air from service piping (A), by proceeding in the following way. Disconnect piping (A) from gaugemanifold and open valve (3) of charge cylinder, for a few seconds. Immediately connect again piping (A) after checking gas goes out properly through piping itself.

**e)** Open valves (1) and (3). Refrigerant starts flowing away from charge cylinder to refrigerant circuit. Keep charge cylinder perfectly upright.

**f)** When free refrigerant flow stops inside refrigerant circuit, it is necessary to operate compressor by starting system in Cooling mode, till amount (weight) of refrigerant introduced inside the circuit is exactly the same of that calculated previously.

**g)** After checking that refrigerant amount inside circuit is correct, close valve (3).

**h)** Disconnect charge piping from the circuit. Protect inlet of needle valve and service valves by special screw caps, by tightening them strictly.





**i)** Check for eventual gas leakages by using a gas leakage detector specific for R410A refrigerant.

**j)** Start the appliance and make sure it operates properly, in particular as far as working pressures (high pressure portion and low pressure portion of refrigerant circuit) and temperature difference ( $\Delta T$ ) between inlet and outlet on Indoor Unit are concerned.

## 6. DIAGNOSTIC & MAINTENANCE

The following table shows a series of apparent malfunctions.

Carry out the checks described below before contacting Authorized Technical Service.

PROBLEM	PROBABLE EXPLICATION
<p>○ After a stop, system does not immediately restart. ○ "Running" lamp flashes.</p> 	<p>○ Air conditioner will restart after 3 minutes have elapsed since it stopped.</p>  <p>○ Each time operation has to restart after a stop of compressor, a 3-minutes protection function intervenes to avoid damages to compressor.</p>
<p>○ At start of operation in Heating mode, Indoor Unit does not supply air.</p>	<p>○ It is necessary to wait for 2 ~ 5 minutes before air will be supplied, to allow pre-heating (funzione "HOT KEEP") of Indoor Unit's heat exchanger and to avoid cool air currents.</p>
<p>○ Indoor Unit keeps on supplying air also after stop of operation in Cooling mode.</p>	<p>○ In this case, indoor fan rotates slowly for some time, so as to remove humidity from heat exchanger and avoid the forming of mould. Air outlet horizontal flap closes after 30 seconds.</p>
<p>○ In Heating mode, Indoor Unit does not supply air for 6 - 12 minutes.</p>	<p>○ If outdoor temperature is low with high humidity, Unit may carry out automatic defrosting. Wait for about 15 minutes. During automatic defrosting, water and vapour come out from Outdoor Unit.</p>
<p>○ In Dry mode, Indoor Unit does not supply air.</p>	<p>○ Sometimes, indoor fan may be stopped to reduce the forming of condensate (possible dripping).</p>
<p>○ In Cooling mode, Indoor Unit emits vapour.</p>	<p>○ This phenomenon may occur if indoor temperature and relative humidity are very high, and ends when temperature and humidity decrease.</p>
<p>○ Indoor Unit emits a disagreeable smell.</p>	<p>○ Indoor Unit treats air inside the room and may absorb odours eventually present in the environment (for example: tobacco, beauty products, etc.).</p>
<p>○ Gurgling or hissing sounds comes out of Indoor Unit.</p> 	<p>○ This is not a malfunction. These sounds are due to refrigerant flowing inside circuit, and are more frequent at start and/or stop of system.</p>
<p>○ Creaking sounds are heard after a system's stop, or after disconnecting the plug from the power socket.</p>	<p>○ This occurs after thermal expansion of Indoor Unit's plastic parts and is not a malfunction.</p>
<p>○ After a blackout, system cannot restart automatically.</p>	<p>○ Microcomputer memory has been reset. Use remote control to restore system's operation.</p>
<p>○ Signals sent by remote control are not received by Indoor Unit. No "beep" sound is heard coming from the buzzer on Indoor Unit.</p>	<p>○ If signal receiver on Indoor Unit is exposed to direct sunlight or to strong lighting, it is possible that signals sent by remote control are not received.</p> <p>○ If there are obstacles in front of IR receiver on Indoor Unit, please remove these obstacles.</p> 
<p>○ Condensate forms on Indoor Unit's air outlets.</p>	<p>○ This occurs if system works for a long time in Cooling mode or in Dry mode in environments where humidity is very high.</p>

**6.1 AUTODIAGNOSIS OF MALFUNCTIONS: ERROR CODES ON INDOOR UNIT**

2-digits LED Display		"Running" lamp 		Description	Cause of malfunction. What it should be checked.
Code	State	Codification	State		
<b>DF</b>	System ON	Flashing once/1sec.		Automatic defrosting	There is no malfunction. At the end of automatic defrosting procedure, the system will restart in Heating mode normally.
	System OFF	Flashing once/3sec.		"HOT KEEP" function	<ol style="list-style-type: none"> <li>1. There is no malfunction, this system's function precedes start of Indoor Unit's fan in Heating mode.</li> <li>2. The intervention of this function will end after Indoor Unit's heat exchanger has reached a temperature sufficient to avoid supplying of cool air by Indoor Unit.</li> </ol>
<b>E2</b>	System OFF	Flashing once/1sec.	System ON & OFF	Malfunction of <b>Tr</b> sensor.	<ol style="list-style-type: none"> <li>1. Measure resistance value [*] of <b>Tr</b> sensor. If temperature is 25°C, this value must be of about 5kΩ. Otherwise, replace <b>Tr</b> sensor.</li> <li>2. Check if there is a short circuit or a break on sensor's wires, and if sensor's connector is properly connected to Indoor Unit's PCB. Correct eventual problems that are observed.</li> <li>3. If checks at previous items 1. and 2. do not remove operating malfunction, sensor circuit on Indoor Unit's PCB is broken and it is necessary to replace the PCB.</li> </ol>
<b>E3</b>	System OFF	Flashing 3times/5sec.	System ON & OFF	Malfunction of <b>TP1</b> sensor.	<ol style="list-style-type: none"> <li>1. Measure resistance value [*] of <b>TP1</b> sensor. If temperature is 25°C, this value must be of about 5kΩ. Otherwise, replace <b>TP1</b> sensor.</li> <li>2. Check if there is a short circuit or a break on sensor's wires, and if sensor's connector is properly connected to Indoor Unit's PCB. Correct eventual problems that are observed.</li> <li>3. If checks at previous items 1. and 2. do not remove operating malfunction, sensor circuit on Indoor Unit's PCB is broken and it is necessary to replace the PCB.</li> </ol>
<b>E4</b>	System ON & OFF	Flashing 4times/6sec.	System OFF	Malfunction of Outdoor Unit	<ol style="list-style-type: none"> <li>1. Measure the resistance of compressor's winding and the value of current which is absorbed by compressor during operation.</li> <li>2. Measure values of high pressure and low pressure on refrigerant circuit, during system's operation.</li> <li>3. Check if resistance [*] (measure it) of <b>TP1</b> sensor is normal. Check if connector of <b>TP1</b> sensor is properly connected to Indoor Unit's PCB.</li> </ol> <p>Measure temperature on evaporator (Indoor Unit) in Cooling mode and check if it corresponds to temperature which is detected by <b>TP1</b> sensor. Check if sensor is well inserted in its slot on evaporator. <b>(to be continued at the following page)</b></p>

2-digits LED Display		"Running" lamp 		Description	Cause of malfunction. What it should be checked.
Code	State	Codification	State		
<b>E4</b>	System ON & OFF	Flashing 4times/6sec.	System OFF	Malfunction of Outdoor Unit	<p><b>(following of previous page)</b></p> <p>4. Check if condenser (heat exchanger on Outdoor Unit) is not dirty outside, etc. Clean it, if it is necessary.</p> <p>5. Check Outdoor Unit's fan motor il motor and corresponding condenser. Replace the component eventually broken.</p> <p>6. If all checks carried out at previous items (from 1. to 5.) have negative result, replace Control PCB on Indoor Unit.</p>
<b>E5</b>	System OFF	Flashing 5times/7sec.	System OFF	Malfunction of indoor fan motor (return signal)	<p>1. Check if both connectors of wires coming out of fan motor are properly inserted on corresponding bases on PCB.</p> <p>2. Check if indoor fan motor is not damaged. If necessary, replace it.</p> <p>3. On Indoor Unit's PCB, check if Control CPU and other components are not damaged. If necessary, replace the broken component or the PCB.</p>
<b>E6</b>	System OFF	Flashing 6times/8sec.	System OFF	Malfunction of indoor fan motor (no rotation)	<p>1. Check fan wheel of fan motor: can it rotate freely?</p> <p>2. On Indoor Unit's Control PCB, check if there is output signal on contacts for fan motor. Otherwise, replace the PCB.</p>
<b>E8</b>	System OFF	Flashing 8times/10sec.	System OFF	Low temperature heat exchanger I.U. (Cooling mode)   High temperature heat exchanger I.U. (Heating mode)	<p>1. Inspect air filters on Indoor Unit's air inlet and eventually clean them, if it is necessary.</p> <p>2. Check if indoor fan rotates properly. If necessary, replace fan motor.</p> <p>3. Check temperature sensor <b>TP1</b> on Indoor Unit's heat exchanger ([*] R-T values) and replace it if necessary.</p> <p>4. Check pressure value on refrigerant circuit. If there are malfunctions, inspect the circuit searching for eventual refrigerant leakages. If there are leakages, eliminate them. Then discharge all refrigerant and recover it, carry out vacuum again and recharge R410A refrigerant.</p>

**Note [\*]:** Tables R-T of sensors' resistances values, according to temperature, are indicated both in "Section 3: Electrical Data" and in this "Section 6: Diagnostic & Maintenance" of this Technical Manual.

**6.2 FLOWCHARTS FOR MALFUNCTIONS' SOLUTION**

■ **Case 1: Malfunction of temperature sensor "Tr" [Indoor Temperature]**

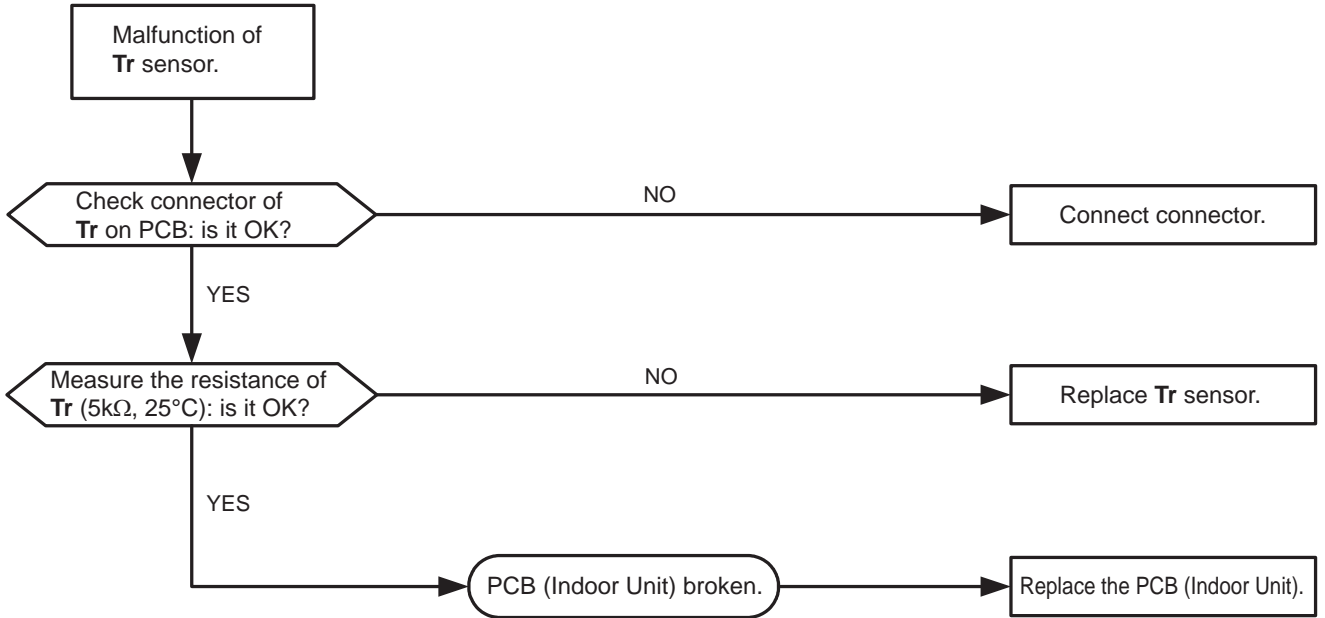

■ **Case 2: Malfunction of temperature sensor "TP1" [Indoor heat exchanger's temperature]**

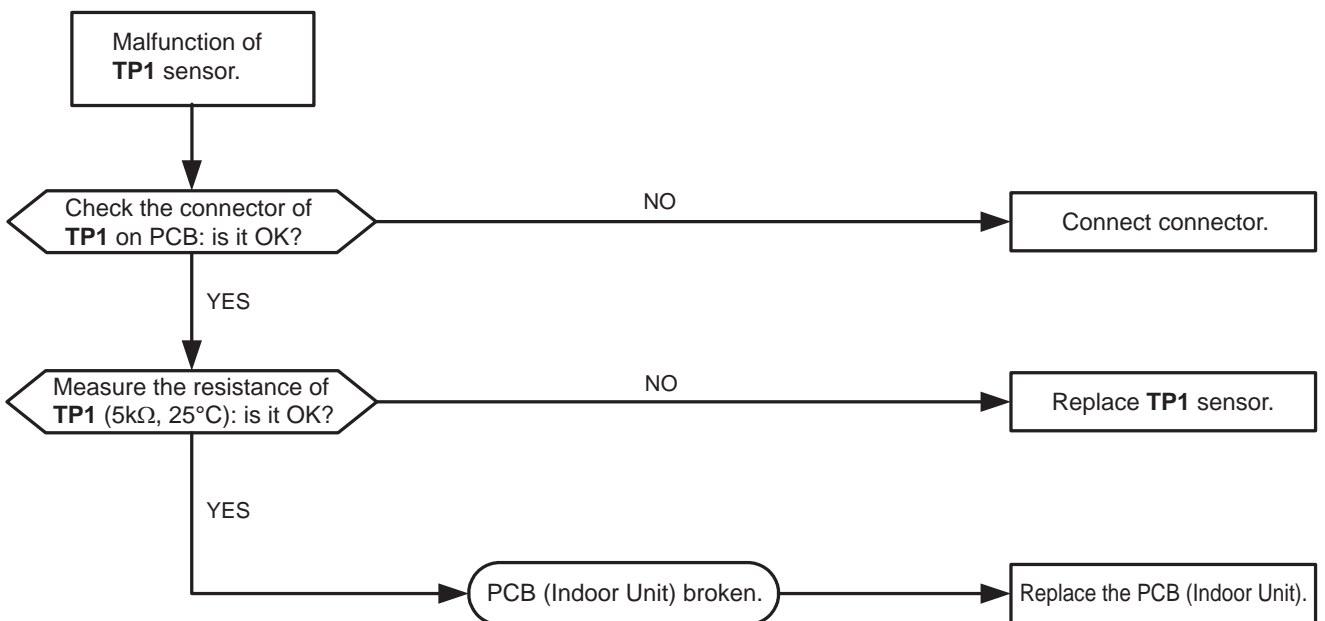

■ **Case 3: Only indoor fan motor does not operate**

○ **Primary check**

- (1) Is it possible to detect the power supply voltage (200~240V) between "L" and "N" on Indoor Unit's terminal block?
- (2) If system operates in Cooling mode, does Indoor Unit's fan motor operate properly?

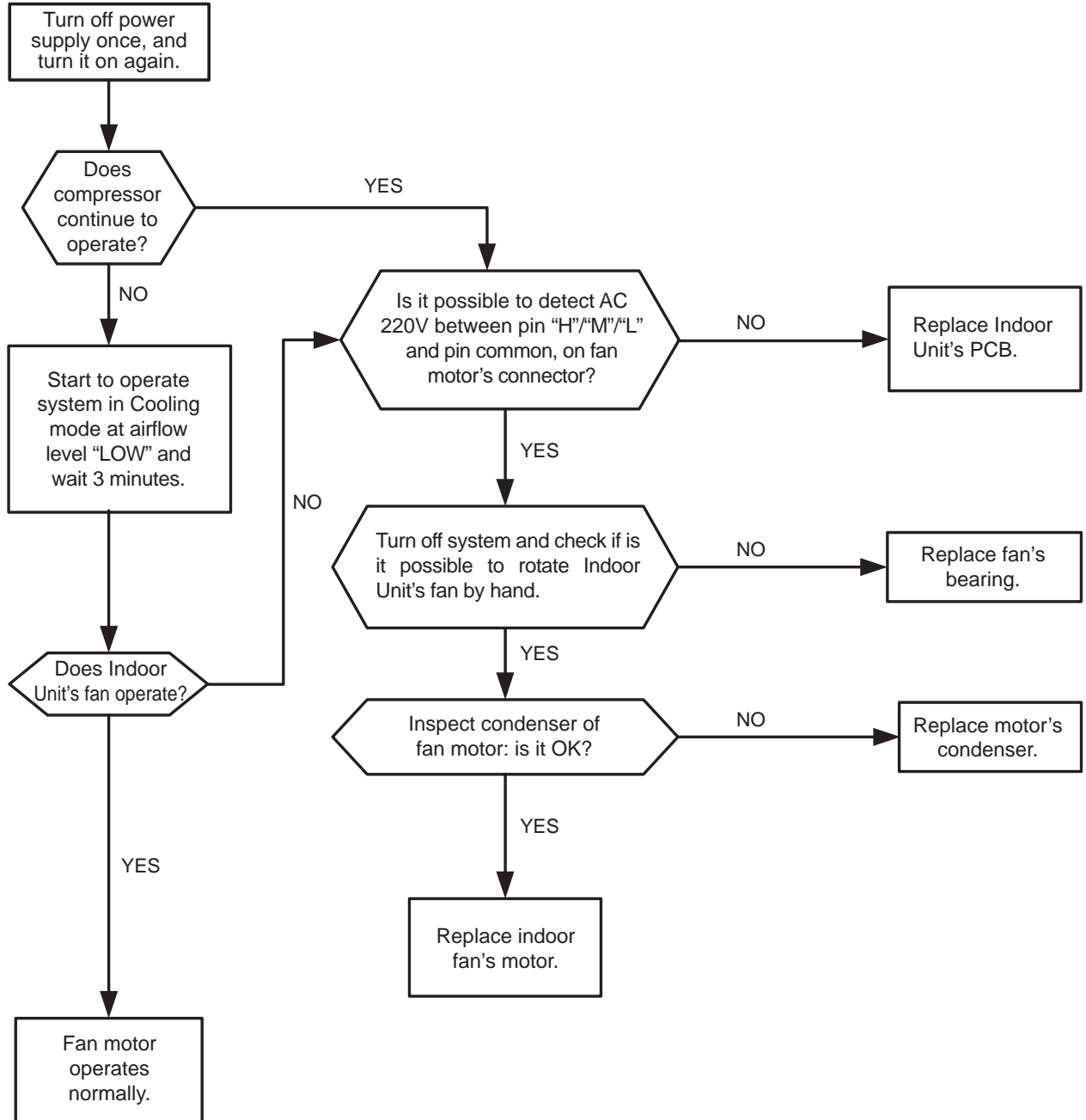

■ **Case 4: Compressor does not operate**

○ **Primary check**

- (1) Is room temperature (**Tr**) higher than preset temperature (**Ts**), in Cooling operation?
- (2) Are crossover cables between Indoor Unit and Outdoor Unit connected properly?

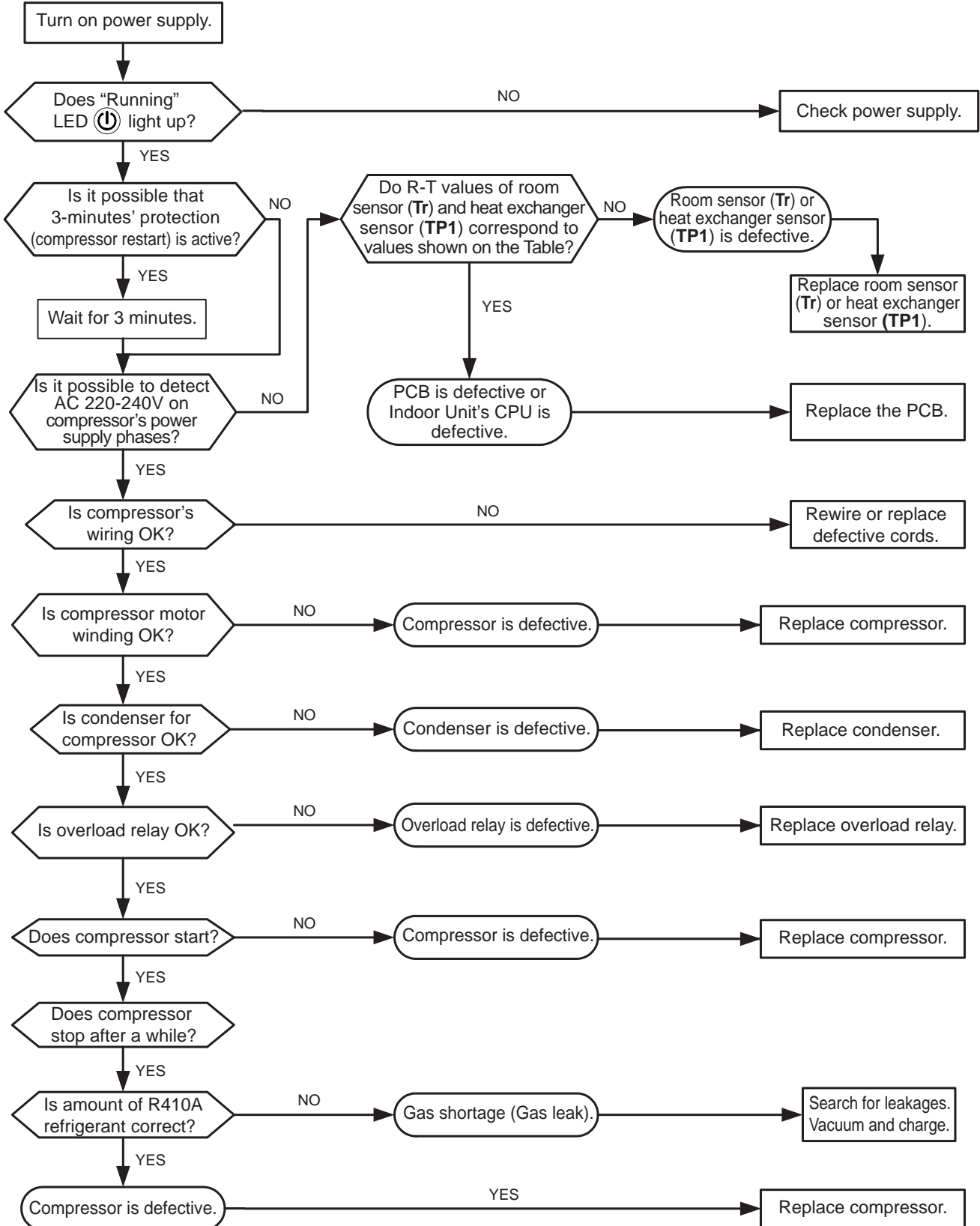

■ **Case 5: Indoor Unit does not receive signals from remote control**

○ **Primary check**

- (1) No "beep" is heard from Indoor Unit to indicate remote control's receiving signals.
- (2) On Indoor Unit, "Running" LED (🔌) does not light up.

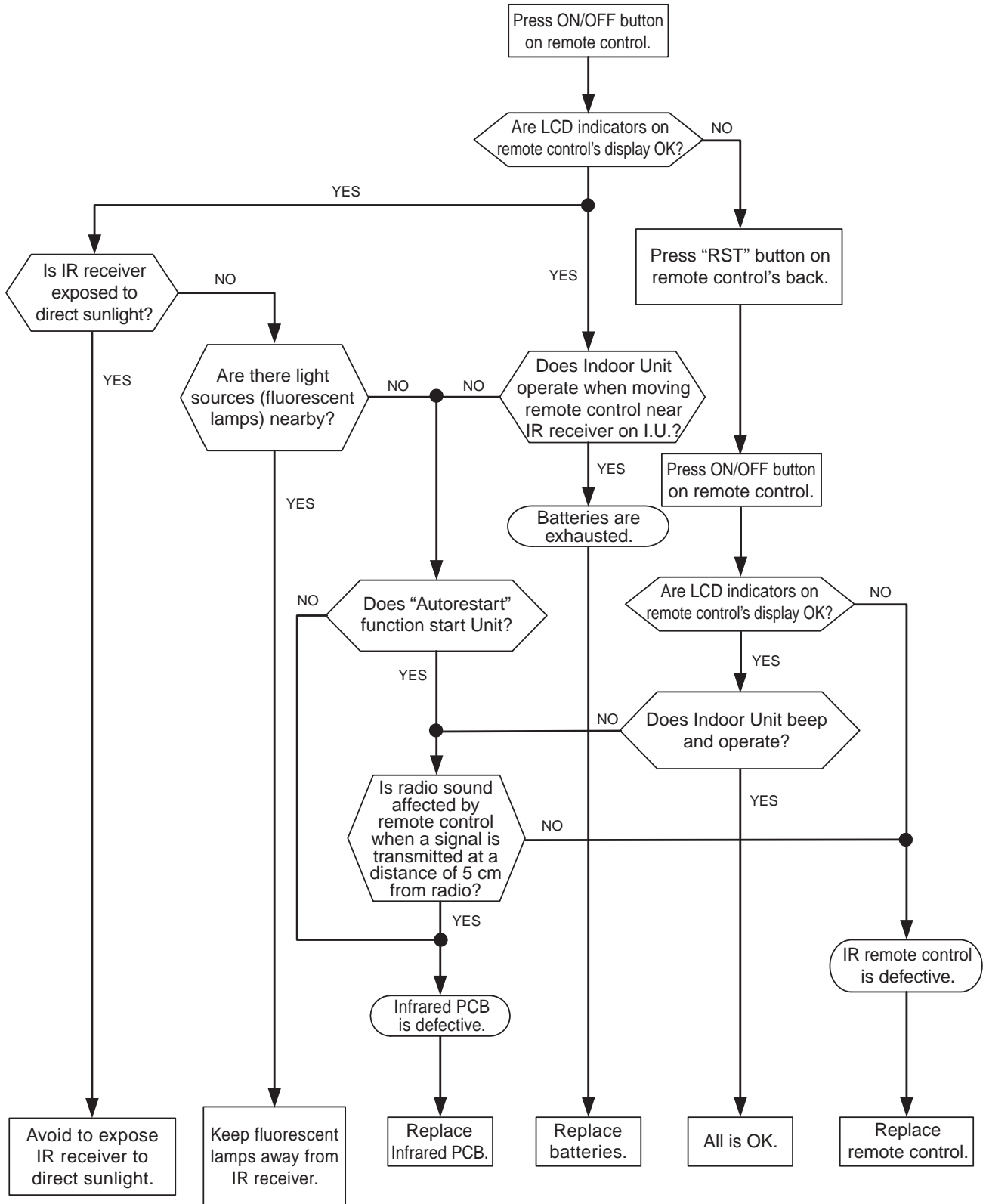

■ Case 6: Indoor Unit does not operate

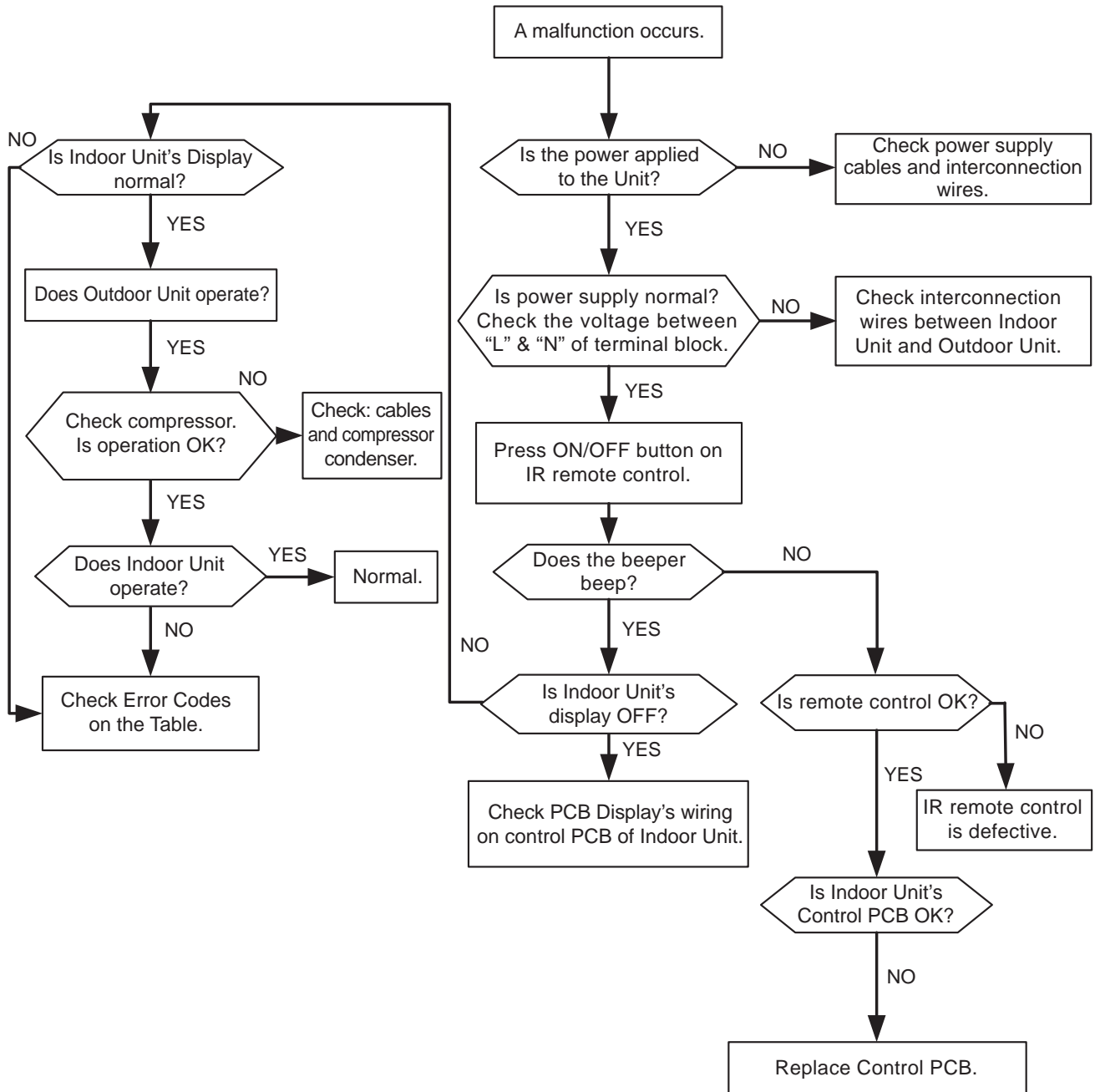

■ Case 7: Indoor Unit and Outdoor Unit do not operate

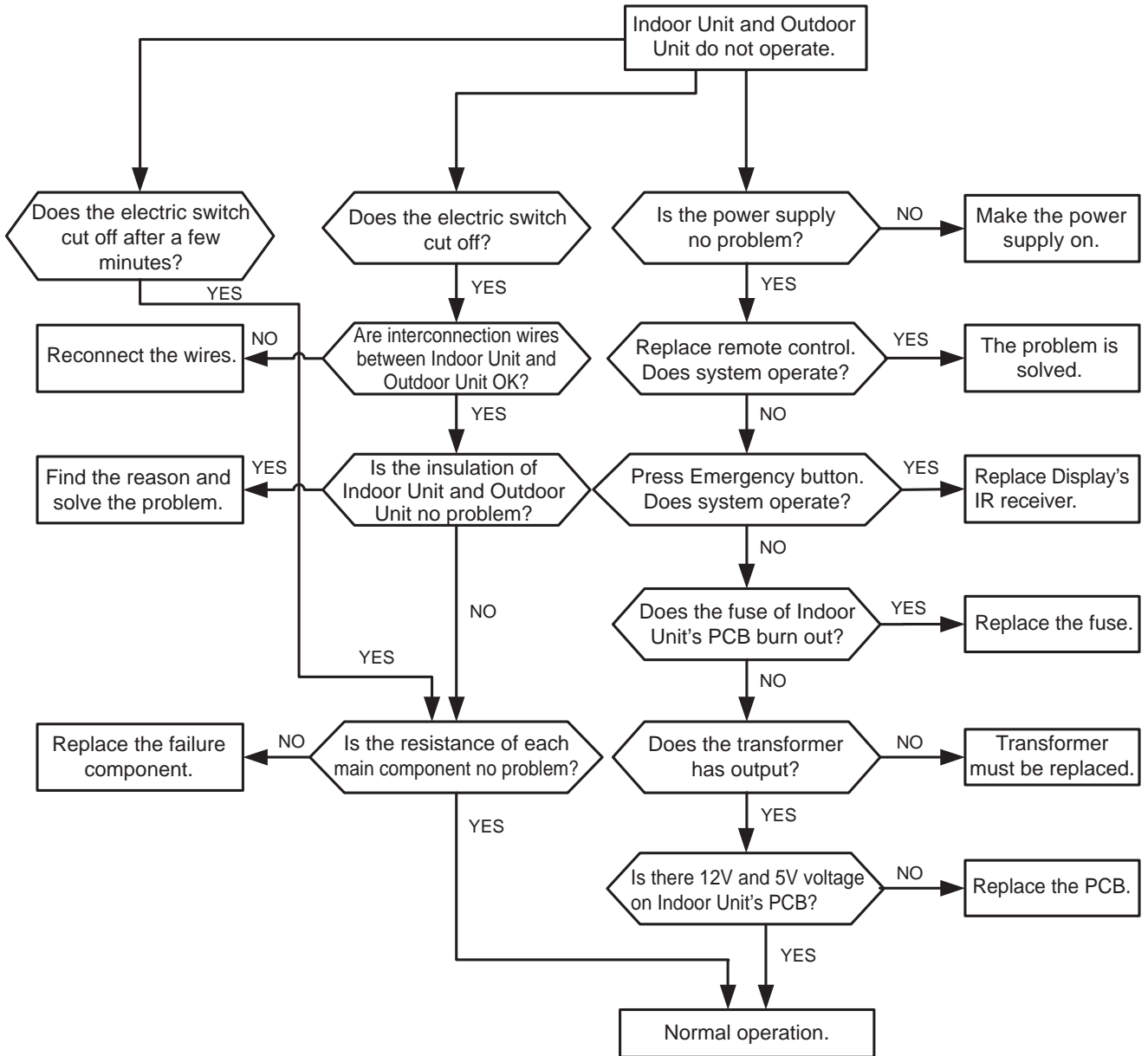

**■ Tables R-T of sensors' resistance values according to temperature**

○Tr (room temperature) | TP1 (heat exchanger's temperature on Indoor Unit)

Temperature (°C)	Resistance Min. (kΩ)	Standard (kΩ)	Resistance Max. (kΩ)	Voltage (5V, 4.3K)		Temperature (°C)	Resistance Min. (kΩ)	Standard (kΩ)	Resistance Max. (kΩ)	Voltage (5V, 4.3K)	
				Down	Up					Down	Up
-30	51.195	52.840	54.521	0.38	4.62	26	4.771	4.821	4.871	2.36	2.64
-29	48.659	50.232	51.805	0.39	4.61	27	4.599	4.649	4.699	2.40	2.60
-28	46.299	47.772	49.248	0.41	4.59	28	4.434	4.485	4.535	2.45	2.55
-27	44.071	45.452	46.832	0.43	4.57	29	4.277	4.327	4.377	2.49	2.51
-26	41.968	43.261	44.554	0.45	4.55	30	4.126	4.176	4.226	2.54	2.46
-25	39.981	41.193	42.405	0.47	4.53	31	3.981	4.031	4.081	2.58	2.42
-24	38.102	39.238	40.375	0.49	4.51	32	3.842	3.892	3.942	2.62	2.38
-23	36.326	37.391	38.457	0.52	4.48	33	3.709	3.759	3.808	2.67	2.34
-22	34.646	35.645	36.645	0.54	4.46	34	3.581	3.631	3.680	2.71	2.29
-21	33.055	33.993	34.931	0.56	4.44	35	3.495	3.508	3.557	2.77	2.23
-20	31.550	32.430	34.310	0.59	4.41	36	3.340	3.389	3.438	2.80	2.20
-19	30.097	30.923	31.748	0.61	4.39	37	3.226	3.275	3.323	2.84	2.16
-18	28.722	29.497	30.271	0.64	4.36	38	3.117	3.165	3.213	2.88	2.12
-17	27.420	28.147	28.873	0.66	4.34	39	3.012	3.06	3.107	2.92	2.08
-16	26.186	26.868	27.55	0.69	4.31	40	2.912	2.959	3.006	2.96	2.04
-15	25.017	25.657	26.297	0.72	4.28	41	2.815	2.861	2.908	3.00	2.00
-14	23.908	24.509	25.11	0.75	4.25	42	2.722	2.768	2.814	3.04	1.96
-13	22.857	23.421	23.98	0.78	4.22	43	2.633	2.678	2.724	3.08	1.92
-12	21.859	22.389	22.918	0.81	4.19	44	2.547	2.529	2.637	3.12	1.88
-11	20.912	21.409	21.907	0.84	4.16	45	2.464	2.509	2.553	3.16	1.84
-10	20.013	20.48	20.917	0.87	4.13	46	2.385	2.429	2.473	3.20	1.80
-9	19.116	19.584	20.023	0.90	4.10	47	2.308	2.352	2.395	3.23	1.77
-8	18.322	18.734	19.146	0.93	4.07	48	2.235	2.278	2.231	3.27	1.73
-7	17.540	17.927	18.314	0.97	4.03	49	2.164	2.207	2.249	3.30	1.70
-6	16.797	17.160	17.524	1.00	4.00	50	2.096	2.138	2.180	3.34	1.66
-5	16.090	16.431	16.733	1.04	3.96	51	2.030	2.071	2.112	3.37	1.63
-4	15.418	15.739	16.060	1.07	3.93	52	1.966	2.006	2.047	3.41	1.59
-3	14.779	15.080	15.382	1.11	3.89	53	1.904	1.944	1.984	3.44	1.54
-2	14.170	14.454	14.737	1.15	3.85	54	1.844	1.884	1.923	3.48	1.52
-1	13.591	13.857	14.124	1.18	3.82	55	1.787	1.826	1.865	3.51	1.49
0	13.040	13.290	13.54	1.22	3.78	56	1.732	1.770	1.809	3.54	1.16
1	12.505	12.739	12.974	1.26	3.74	57	1.679	1.717	1.754	3.57	1.43
2	11.995	12.215	12.436	1.30	3.70	58	1.628	1.665	1.702	3.60	1.40
3	11.509	11.717	11.924	1.34	3.66	59	1.579	1.615	1.652	3.63	1.37
4	11.047	11.241	11.436	1.38	3.62	60	1.531	1.567	1.603	3.66	1.34
5	10.606	10.789	10.971	1.42	3.58	61	1.485	1.521	1.556	3.69	1.31
6	10.186	10.357	10.529	1.47	3.53	62	1.441	1.476	1.511	3.72	1.28
7	9.785	9.945	10.107	1.51	3.49	63	1.399	1.433	1.467	3.75	1.25
8	9.403	9.554	9.705	1.55	3.45	64	1.357	1.391	1.425	3.78	1.22
9	9.038	9.180	9.322	1.59	3.41	65	1.318	1.351	1.384	3.80	1.20
10	8.690	8.823	8.956	1.64	3.36	66	1.279	1.312	1.344	3.83	1.17
11	8.357	8.482	8.607	1.68	3.32	67	1.242	1.274	1.306	3.86	1.14
12	8.040	8.157	8.274	1.73	3.27	68	1.206	1.237	1.269	3.88	1.12
13	7.736	7.816	7.957	1.77	3.23	69	1.171	1.202	1.233	3.91	1.09
14	7.446	7.550	7.653	1.81	3.19	70	1.137	1.168	1.199	3.93	1.07
15	7.169	7.226	7.363	1.86	3.14	71	1.105	1.135	1.165	3.96	1.04
16	6.900	6.991	7.082	1.90	3.10	72	1.074	1.103	1.133	3.98	1.02
17	6.644	6.729	6.814	1.95	3.05	73	1.043	1.072	1.101	4.00	1.00
18	6.398	6.478	6.558	1.99	3.01	74	1.014	1.043	1.071	4.02	0.98
19	6.163	6.238	6.313	2.04	2.96	75	0.986	1.014	1.042	4.05	0.95
20	5.938	6.008	6.078	2.09	2.91	76	0.959	0.986	1.014	4.07	0.93
21	5.723	5.789	5.854	2.13	2.87	77	0.932	0.959	0.986	4.09	0.91
22	5.517	5.578	5.64	2.18	2.82	78	0.907	0.933	0.960	4.11	0.89
23	5.320	5.377	5.484	2.22	2.78	79	0.882	0.908	0.934	4.13	0.87
24	5.131	5.185	5.238	2.27	2.73	80	0.858	0.884	0.910	4.15	0.85
25	4.950	5	5.05	2.31	2.69	81					

### 6.3 CLEANING & MAINTENANCE OF AIR CONDITIONER

■ **Cleaning of air filters (high-efficiency, net type)**

**⚠ CAUTION**

○ **Before beginning cleaning operations:**

1. Stop system by pressing ON/OFF button on remote control.
2. Move main power switch on "OFF" or "0".
3. Pull out the plug from power socket.
4. To reach Indoor Unit, use a stepladder of other appropriate bearing strong enough to ensure your safety.

If air filters, of net type, are blocked by dirt or dust, performances of system in Cooling mode or in Heating mode will be affected. At the same time, electric absorptions and noise level during operation of system will be increased.

Therefore, air filters must be cleaned regularly (at least every 2 weeks).

To carry out the cleaning correctly, observe the following Instructions or contact Authorized Technical Service.

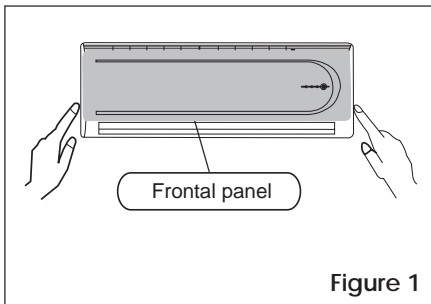

**1) Remove air filters from Indoor Unit.**

- Gently press on both sides and bottom of frontal panel, then pull the panel towards you (see Figure 1) till max. opening. Opening angle of frontal panel must never be more than 60°.
- Gently lift each filter and remove it by pulling it towards you (Figure 2).

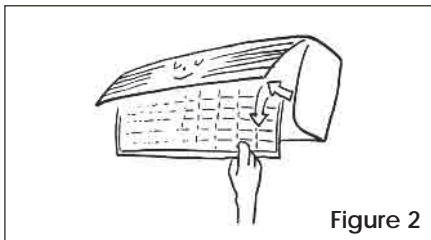

**⚠ WARNING**

After removing the filters, take care not to touch metal parts below (sharp fins of heat exchanger), as there is the risk of injuries.

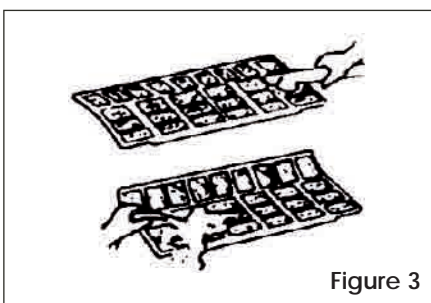

**2) Cleaning and drying of Indoor Unit's air filters**

- Clean air filters by using a vacuum cleaner. Select min. power.
- If filters are very dirty, wash them in lukewarm water (max. 30°C): see Figure 3).
- Dry filters in shaded place and away from heat sources.
- Do not exert too much force in pulling and stretching filters.

**3) Reinstalling of air filters on Indoor Unit**

- Do not start system if Indoor Unit has no filter or if air filters are damaged. This makes foreign bodies enter Indoor Unit and causes deposit of dust and other impurities on heat exchanger, with possible damages to mechanical moving parts placed inside Unit.

■ **Cleaning of Indoor Unit and Remote Control**

**⚠ CAUTION**

○ **Before beginning cleaning operations:**

1. Stop system by pressing ON/OFF button on remote control.
2. Move main power switch on "OFF" or "0".
3. Pull out the plug from power socket.
4. To reach Indoor Unit, use a stepladder of other appropriate bearing strong enough to ensure your safety.

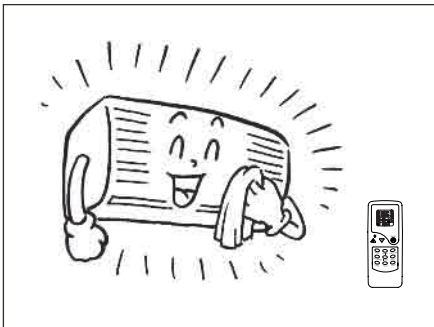

- For cleaning of Indoor Unit and Remote Control, use a soft and dry cloth, or a vacuum cleaner by adjusting it at min. power.  
If Indoor Unit is very dirty, use a cloth soaked in lukewarm water (about 30°C) and neutral detergent.
- Wash with clean water and dry well, as the presence of humidity on Indoor Unit's inlet grille may cause electric shocks.



**⚠ CAUTION**

Never use water for cleaning inside parts. If water enters inside, insulation system may be damaged, with consequent risk of electric shocks.

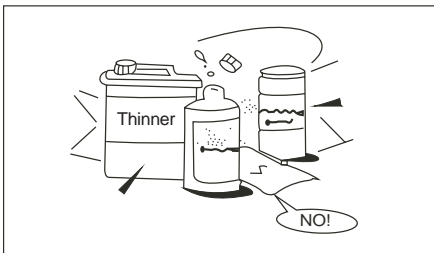

- For cleaning of Remote Control, never use clothes soaked in water.
- For cleaning of Units, never use petrol, thinner, polishing powder or any similar solvents, etc.
- In general, chemical products may crack or deform the plastic and painted surfaces of Units.

**🗉 Notes:**

- For cleaning of Indoor Unit, do not use abrasive sponges, thus avoiding to scratch Indoor Unit's surfaces.
- If Indoor Unit's frontal panel is open or has been removed, do not touch aluminium fins of heat exchanger, as fins' profile is sharp.
- Do not expose Indoor Unit's grille or the Indoor Unit itself to direct sunlight, to avoid discolouring or deformation.

■ **Outdoor Unit's cleaning**

Check regularly that air inlet and outlet on Outdoor Unit are not obstructed by dust or any other impurities.

Any extraordinary cleaning or maintenance intervention on Outdoor Unit, must be always carried out by Authorized Technical Service.

■ Ordinary maintenance: at the beginning of season

☞ At the beginning of each season or after a long period during which the system has not been used, carry out the following checks:

1. Air inlet and outlet must be free from obstacles

○ Carry out this check both on Indoor Unit and on Outdoor Unit.

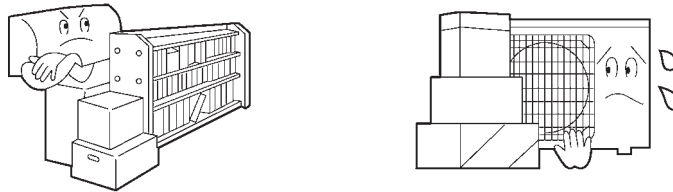

2. Fixing devices on Units must allow a safety operation

○ Fixing devices may be subject to corrosion and must be checked regularly to prevent any possible collapse of Units.

3. Grounding Wires

○ Grounding wires must be carried out professionally.  
This is essential for correct operation of system and for Safety.

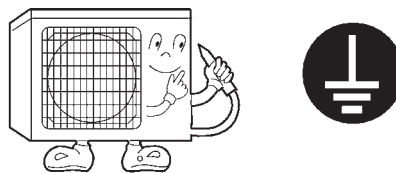

**⚠ CAUTION**

○ In case of incorrect Grounding wires, there is the risk of electric shocks

4. Air filters on Indoor Unit

○ If air filters have been removed or are damaged, reinstall them and eventually replace them. Filters must be cleaned at the beginning of each season.

5. Batteries of IR remote control

○ Batteries that are previously removed must be fitted again into remote control after checking they are charged.

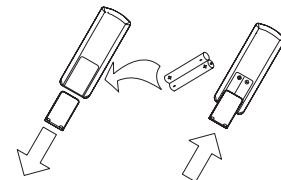

6. Power supply of system

○ Supply power to the system a few hours before starting it, by inserting the plug into the power socket and moving main switch to "ON" or "I".

○ At the end of this time, it is possible to start system's operation by pressing ON/OFF button on remote control.

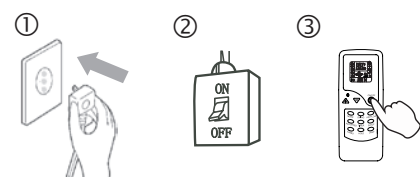

■ Ordinary maintenance: at the end of season

☞ At the end of each season, if you foresee a period during which the air conditioner is not used, please carry out the following devices:

1. Remove remaining humidity from Indoor Unit

- Operate system for some hours, by selecting "FAN" only mode and "HIGH" fan speed. This may allow to remove remaining humidity from Indoor Unit, and reduce the risk of forming of mould and bad smells during time when system is not used.



About 2 hours

2. Disconnect the system

- Stop the system by pressing "ON/OFF" on remote control.
- Move power supply main switch to "OFF" or "0".
- Disconnect the plug from the power socket.

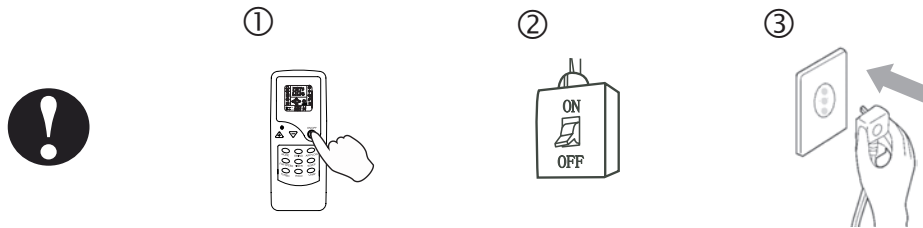

3. Remove, clean and reinsert air filters on Indoor Unit

- In this way, Indoor Unit will be ready for use in following season.



4. Clean Indoor Unit and Outdoor Unit

- Clean Indoor Unit and Outdoor Unit as it has already been explained previously.
- In particular, protect Outdoor Unit by a waterproof cover that can be easily found on the market.

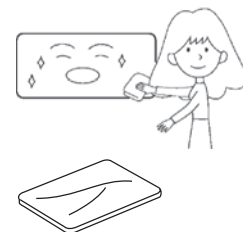

5. Remove batteries from IR remote control

- Carry out this operation so as to prevent acid from coming out of batteries themselves. Acid may damage contacts inside battery case.

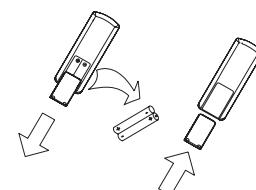











**HOKKAIDO ITALIA SRL**

14, Via della Salute

40132 Bologna - Italy

Tel. +39.051.41.33.111

Fax +39.051.41.33.146

[www.hokkaido.it](http://www.hokkaido.it)

**HOKKAIDO**

Due to on-going technological development of Products by Manufacturer, we reserve the right to vary the technical specifications at any time without notice.